



20
24

MEINL PERCUSSION





B	
Bags	100
Blocks	18
Bongos	60
Bongo Cajons	38/42
Brushes/Beaters	31/43/88

C	
Cabasas	20
Caixas	83
Cajons	34
Cajons, Bass	39
Cajons, Pickup	40
Cajons, Slaptop	38
Cajon Add-Ons	48
Cajon Drum Sets	44
Cajon Pedals	43
Castanets	19
Chimes	28
Ching Rings	07
Claves	19
Congas	64
Cowbells	16

D	
Darbukas	76
Didgeridoos	24
Djembes	50
Djembe, Pickup	54
Djembes, Synthetic	50
Djembes, Wood	56
Doumbeks	77
Drum Rugs	105
Drummer Snare Timbales	75

F	
Foot Percussion	30
Frame Drums	84

G	
Güiros	18
Güiras	21

H	
Hand Drums	84
Hand Percussion	02
Hardware	96

I	
Ibo Drums	86

J	
Jingle Sticks	08

K	
Kalimbas	20

M	
Mallets	88
Maracas	15

P	
Pandeiros	09
Percussion Snares	75
Pickup Accessories	41/46

R	
Rainsticks/Rainmaker	26
Ritual Drums	86
Riq Drum	09

S	
Samba	21/80
Shakers	10/21
Shekeres	87
Sound Effects	22
Stands	90
Sticks/Scrapers	88
Stomp Boxes	30
Surdos	80

T	
Tables	94
Tamborims	83
Tambourines	02/11
Tamburello	04
Timbales	74
Triangles	22

COMPACT WOOD TAMBOURINES

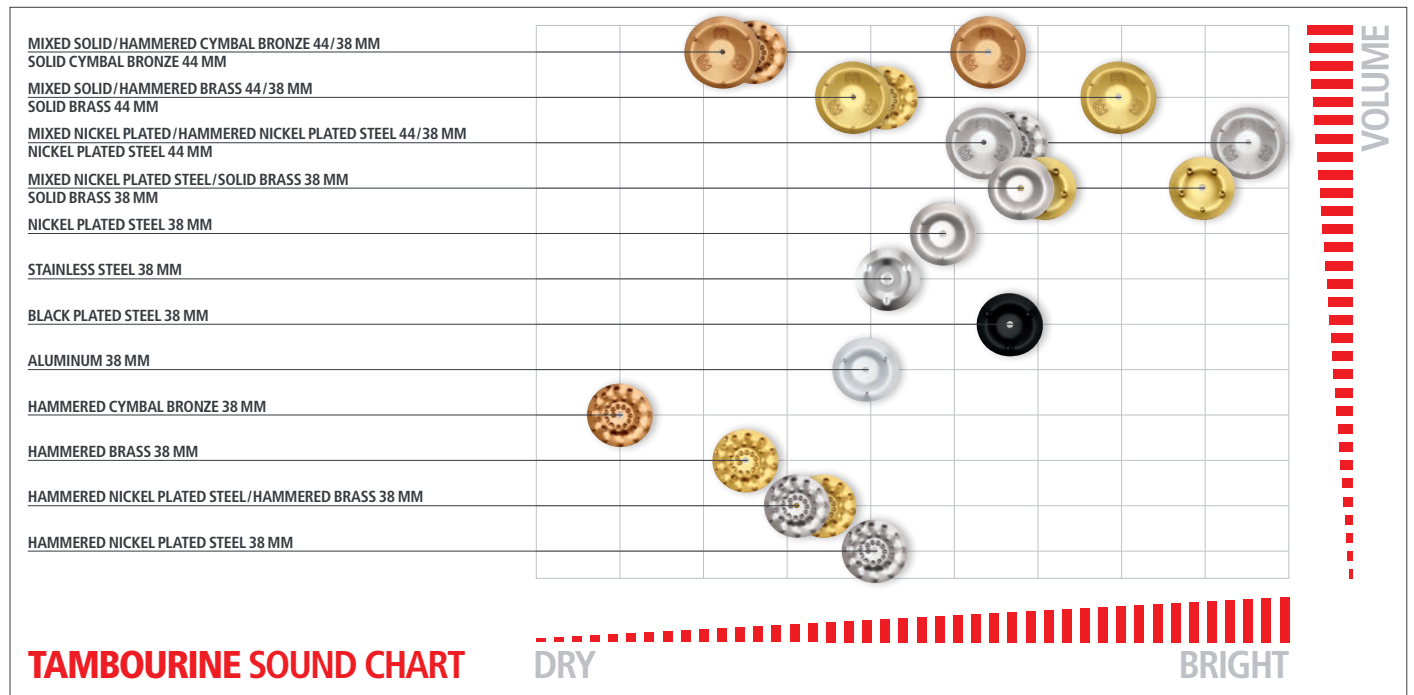

<p>1</p>  <p>3 rows AE-CMTA3BO</p> <p>HAMMERED CYMBAL BRONZE</p>	<p>2</p>  <p>2 rows CTA2B-BK</p> <p>SOLID BRASS</p>	 <p>2 rows CTA2M-BK</p> <p>MIXED NICKEL PLATED STEEL / SOLID BRASS</p>	 <p>2 rows CTA2S-BK</p> <p>NICKEL PLATED STEEL</p>
 <p>3 rows AE-CMTA3B</p> <p>HAMMERED BRASS</p>	 <p>3 rows AE-CATA3S</p> <p>HAMMERED NICKEL PLATED STEEL</p>	 <p>2 rows CTA2VM-WB</p> <p>MIXED HAMMERED NICKEL PLATED STEEL / BRASS</p>	 <p>2 rows CTA2WB</p> <p>STAINLESS STEEL</p>

1 ARTISAN EDITION COMPACT TAMBOURINES

SIZE 8"

MATERIALS **AE-CATA3:** American White Ash (*Fraxinus americana* L.)
AE-CMTA3: Maple (*Adcer* sp.)
B: Hammered brass jingles
BO: Hammered cymbal bronze jingles
S: Hammered nickel plated steel jingles

FEATURES Total unique tambourine sounds; Resounding jingle accents; Special profile jingles; Ergonomic hand grip; Detailed with ornamental heat-branded logo; 3 rows of hammered jingles; Extra narrow jingle slots for precise playing

2 COMPACT WOOD TAMBOURINES

SIZE 8"

MATERIALS Wooden frame
CTA2B-BK: Solid brass jingles
CTA2M-BK: Nickel plated steel / solid brass jingles
CTA2S-BK: Nickel plated steel jingles
CTA2VM-WB: Hammered nickel plated steel / hammered brass jingles
CTA2WB: Stainless steel jingles

FEATURES Compact size; 2 row version

COLOURS **BK:** Black
WB: Walnut Brown

WOOD TAMBOURINES



TAMBOURINES

1

1 row
AE-MTA1BO

2 rows
AE-MTA2BO

SOLID CYMBAL
BRONZE 44 MM

1 row
AE-MTA1B

2 rows
AE-MTA2B

SOLID BRASS 44 MM

1 row
AE-ATA1S

2 rows
AE-ATA2S

NICKEL PLATED
STEEL 44 MM

2

1 row
TA1V-WB

2 rows
TA2V-WB

HAMMERED BRASS

1 row
TA1B-AB

2 rows
TA2B-AB

SOLID BRASS

1 row
TA1AB

2 rows
TA2AB

NICKEL
PLATED STEEL

1 row
TA1VM-WB

2 rows
TA2VM-WB

MIXED
HAMMERED NICKEL
PLATED STEEL / BRASS

1 row
TA1WB

2 rows
TA2WB

STAINLESS STEEL

1 row
TA1A-AB

2 rows
TA2A-AB

ALUMINUM

4

1 row
TA1M-SNT

2 rows
TA2M-SNT

MIXED
NICKEL PLATED
STEEL / SOLID BRASS

5

2 rows
VR-TA2-ROM

1 ARTISAN EDITION TAMBOURINES

SIZE 10"

MATERIALS **AE-ATA:** American White Ash (*Fraxinus americana* L.)
AE-MTA: Maple (*Adcer* sp.)
B: Solid brass jingles
BO: Solid cymbal bronze jingles
S: Nickel plated steel jingles

FEATURES Total unique tambourine sounds; Resounding tambourine accents; Special profile jingles; Ergonomic hand grip; Detailed with ornamental heat-branded logo; 1 row and 2 row version

2 VINTAGE WOOD TAMBOURINES

SIZE 10"

MATERIALS Wooden frame
TA1V: Hammered brass jingles
TA1VM: Hammered nickel plated steel / hammered brass jingles

FEATURES Legendary tambourine sound; Special profile jingles; Detailed with heat-branded logo; 1 row and 2 row version

COLOUR **WB:** Walnut Brown

3 TRADITIONAL WOOD TAMBOURINES

SIZE 10"

MATERIALS Wooden frame
TA1A-AB, TA2A-AB: Aluminum jingles
TA1B-AB, TA2B-AB: Solid brass jingles
TA1AB, TA2AB: Nickel plated steel jingles
TA1WB, TA2WB: Stainless steel jingles

FEATURES 1 row and 2 row version
TA1WB, TA2WB: Detailed with heat-branded logo

COLOURS **AB:** Antique Brown
WB: Walnut Brown

4 RECORDING-COMBO WOOD TAMBOURINES

SIZE 10"

MATERIALS Wooden frame
Nickel plated steel / solid brass jingles

FEATURES Dual-alloy jingles; 1 row and 2 row version

COLOUR **SNT:** Super Natural

5 WOOD TAMBOURINE

SIZE 10"

MATERIALS Black plated steel jingles
Siam Oak (*Hevea brasiliensis* Muell.-Arg.)

FEATURES Double row; Ergonomic grip

FINISH Red/orange marble

HEADED WOOD TAMBOURINES

<p>1</p>  <p>MIXED SOLID / HAMMERED CYMBAL BRONZE</p> <p>2 rows AE-MTAH2BO</p>	 <p>MIXED SOLID / HAMMERED BRASS</p> <p>2 rows AE-MTAH2B</p>	 <p>MIXED NICKEL PLATED / HAMMERED NICKEL PLATED STEEL</p> <p>2 rows AE-ATAH2S</p>	<p>2</p>  <p>TAMBURELLO</p> <p>2 rows FD12TAM</p> <p>ALUMINUM</p>
<p>3</p>  <p>HAMMERED BRASS</p> <p>1 row TAH1V-WB</p> <p>2 rows TAH2V-WB</p>	<p>4</p>  <p>BLACK PLATED STEEL</p> <p>1 row TAH1BK-R-TF</p> <p>2 rows TAH2BK-R-TF</p>	<p>5</p>  <p>MIXED NICKEL PLATED STEEL / SOLID BRASS</p> <p>1 row TAH1M-SNT</p> <p>2 rows TAH2M-SNT</p>	
<p>6</p>  <p>SOLID BRASS</p> <p>1 row TAH1B-AB</p> <p>2 rows TAH2B-AB</p>	 <p>NICKEL PLATED STEEL</p> <p>1 row TAH1AB</p> <p>2 rows TAH2AB</p>	 <p>STAINLESS STEEL</p> <p>1 row TAH1WB</p> <p>2 rows TAH2WB</p>	 <p>ALUMINUM</p> <p>1 row TAH1A-AB</p> <p>2 rows TAH2A-AB</p>

1 HEADED ARTISAN EDITION TAMBOURINES

SIZE 10"

MATERIALS Hand selected calfskin heads
AE-ATAH: American White Ash (*Fraxinus americana* L.)
AE-MTAH: Maple (*Adcer sp.*)
B: Solid / hammered brass jingles
BO: Solid / hammered cymbal bronze jingles
S: Nickel plated / hammered nickel plated steel jingles

FEATURES Total unique tambourine sounds; Resounding jingle accents; Two different profile jingles; Ergonomic hand grip; Detailed with ornamental heat-branded logo; Prepared with Resin

2 TAMBURELLO

SIZE 12"

MATERIALS Wooden frame; Hand selected goatskin head; Aluminum jingles

FEATURES 2 row version; Detailed with heat-branded logo; Total unique tambourine sounds

3 VINTAGE GOATSKIN WOOD TAMBOURINES

SIZE 10"

MATERIALS Wooden frame; Hand selected goatskin heads; Hammered brass jingles

FEATURES 1 row and 2 row version; Detailed with heat-branded logo

COLOUR **WB:** Walnut Brown

4 TOURING SYNTHETIC HEAD WOOD TAMBOURINES

SIZE 10"

MATERIALS Wooden frame; True Feel synthetic heads; Black plated steel jingles

FEATURE 1 row and 2 row version
COLOUR **R:** Red

5 RECORDING-COMBO GOATSKIN WOOD TAMBOURINES

SIZE 10"

MATERIALS Wooden frame; Hand selected goatskin heads; Nickel plated steel / solid brass jingles

FEATURES Dual-alloy jingles; 1 row and 2 row version

COLOUR **SNT:** Super Natural

6 TRADITIONAL GOATSKIN WOOD TAMBOURINES

SIZE 10"

MATERIALS Wooden frame; Hand selected goatskin heads
TAH1A-AB, TAH2A-AB: Aluminum jingles

HAND HELD ABS TAMBOURINES



TAMBOURINES

7

1 row, 8" **HTT8BK** 2 rows, 10" **HTT10BK** 1 row, 8" **HTT8R** 2 rows, 10" **HTT10R** 1 row, 8" **HTT8WH** 2 rows, 10" **HTT10WH**

STAINLESS STEEL

8

1 row **HTBK** 2 rows **HTMT1BK** 1 row **HTR** 2 rows **HTMT1R** 1 row **HTWH** 2 rows **HTMT1WH**

STAINLESS STEEL

9

2 rows **TMT1B-BK** **SOLID BRASS** 2 rows **TMT1BK** **NICKEL PLATED STEEL**

2 rows **TMT1R** **NICKEL PLATED STEEL** 2 rows **TMT1A-B** **ALUMINUM**

10

2 rows **TMT1M-BK** **MIXED NICKEL PLATED STEEL / SOLID BRASS**

2 rows **TMT1M-WH**

TAH1B-AB, TAH2B-AB:

Solid brass jingles

TAH1AB, TAH2AB:

Nickel plated steel jingles

TAH1WB, TAH2WB:

Stainless steel jingles

FEATURES 1 row and 2 row version

TAH1WB, TAH2WB: Detailed with heat-branded logo

COLOURS **AB:** Antique Brown

WB: Walnut Brown

7 HEADLINER® SERIES TOUR TAMBOURINES

SIZES **HTT8:** 8"
HTT10: 10"

MATERIALS Molded ABS; Stainless steel jingles

FEATURES Handheld; Extra wide grip; Bright, cutting sound; Durable frame

HTT8: 1 row version; Compact size

HTT10: 2 row version

COLOURS **BK:** Black

R: Red

WH: White

8 HEADLINER® SERIES HAND HELD ABS TAMBOURINES

MATERIALS Molded ABS; Stainless steel jingles

FEATURES Ergonomic hand grip for more playing comfort; Güiro style playing surface; Penetrating jingle sound

HT: 1 row version

HTMT1: 2 row version

COLOURS **BK:** Black

R: Red

WH: White

9 TRADITIONAL HAND HELD ABS TAMBOURINES

MATERIALS Molded ABS

TMT1A-B: Aluminum jingles

TMT1B-BK: Solid brass jingles

TMT1BK, TMT1R: Nickel plated steel jingles

FEATURES Padded soft grip for more playing comfort; Ergonomic design; Güiro style playing surface; "Sandwich" construction

COLOURS **B:** Blue

BK: Black

R: Red

10 RECORDING-COMBO HAND HELD ABS TAMBOURINES

MATERIALS Molded ABS; Nickel plated steel / solid brass jingles

FEATURES Padded soft grip for more playing comfort; Ergonomic design; Güiro style playing surface; "Sandwich" construction

COLOURS **BK:** Black

WH: White

MOUNTABLE ABS TAMBOURINES

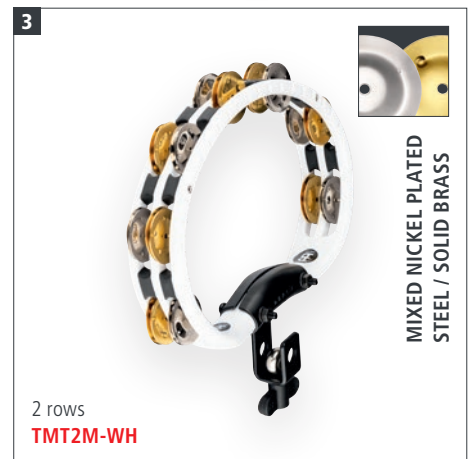
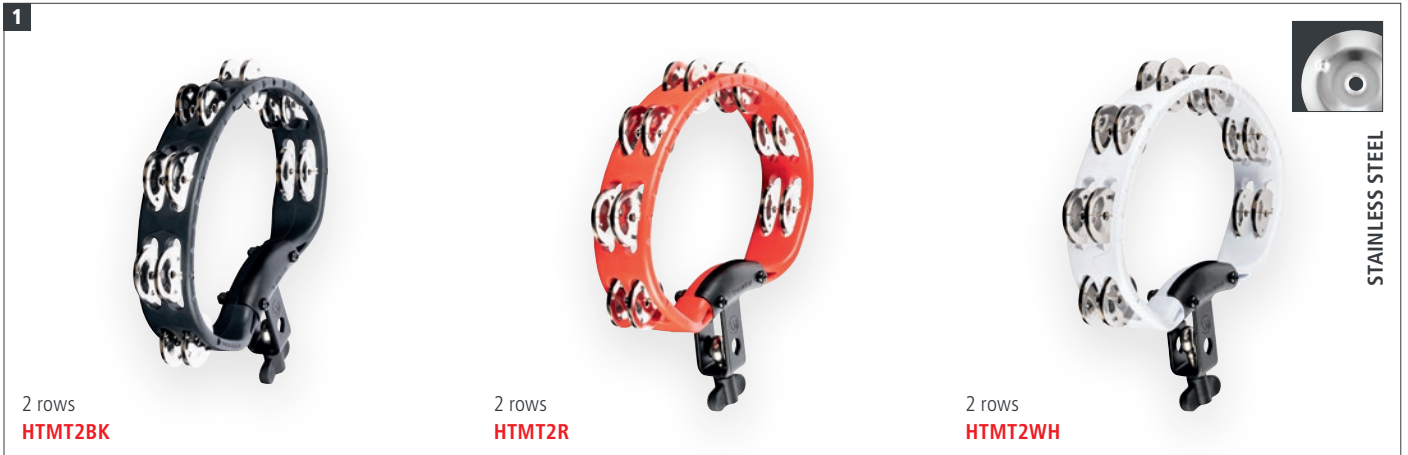

1 HEADLINER® SERIES MOUNTABLE ABS TAMBOURINES

MATERIALS Molded ABS
Stainless steel jingles

FEATURES Easy mountable
Güiro style playing surface
Penetrating jingle sound

COLOURS **BK:** Black
R: Red
WH: White

2 TRADITIONAL MOUNTABLE ABS TAMBOURINES

MATERIALS Molded ABS
TMT2A-B: Aluminum jingles
TMT2B-BK: Solid brass jingles
TMT2BK, TMT2R: Nickel plated steel jingles

FEATURES Easily mountable
Ergonomic design
Güiro style playing surface
"Sandwich" construction

COLOURS **B:** Blue
BK: Black
R: Red

3 RECORDING-COMBO MOUNTABLE ABS TAMBOURINE

MATERIALS Molded ABS
Nickel plated steel / solid brass jingles

FEATURES Easily mountable
Ergonomic design
Güiro style playing surface
"Sandwich" construction

COLOUR **WH:** White

CHING RINGS & HIHAT TAMBOURINES



TAMBOURINES



SFHHT



Ching Ring
CRING

STAINLESS STEEL



Dry Ching Ring
DCRING

ZINC



Soft Ching Ring
SCRING

STAINLESS STEEL



1 row
HTHHBG

SAND HIHAT TAMBOURINE
DESIGNED WITH BENNY GREB



1 row
HTHH1B-BK

HAMMERED BRASS



2 rows
HTHH2B-BK

HAMMERED BRASS



1 row
THH1B-BK

SOLID BRASS



1 row
HTHH1BK

STAINLESS STEEL



2 rows
HTHH2BK

STAINLESS STEEL



1 row
THH1BK

STAINLESS STEEL

1 SUPER FLEX HIHAT TAMBOURINE

- SIZE** 4.3" inner diameter, 9.5" outer diameter
- MATERIALS** Mylar frame
10 pairs of stainless steel jingles
- FEATURES** Super flex frame produces enhanced hihat tambourine accents
10 pairs of stainless steel jingles deliver a clear and bright sound
Extra-wide 9.5" shape gives you outstanding foot response
Shines through the mix to easily blend a tambourine effect into your grooves

2 CHING RINGS

- SIZE** 6"
- MATERIALS** CRING
Steel ring
5 pairs of stainless steel jingles

DCRING

- Steel ring
5 pairs of zinc jingles

SCRING

- Foam ring
6 pairs of stainless steel jingles
- FEATURES** Fits on most cymbals
Quick setup

3 BENNY GREB SAND HIHAT TAMBOURINE

- SIZE** 5"
- MATERIAL** Sand blasted brass jingles
- FEATURES** Benny Greb signature hihat tambourine
Eight pairs of sand blasted brass jingles
Dry, vintage sound with unique matte appearance
Blends easily into your natural drum set or percussion mix
Wing nut design fits on any hihat rod

4 HEADLINER® SERIES HIHAT TAMBOURINES

- SIZE** 5"
- MATERIALS** HTHH1BK, HTHH2BK: Stainless steel jingles
HTHH1B-BK, HTHH2B-BK: Hammered brass jingles
- FEATURE** 1 row and 2 row version

5 PROFESSIONAL SERIES HIHAT TAMBOURINES

- SIZE** 5"
- MATERIALS** THH1BK: Stainless steel jingles
THH1B-BK: Solid brass jingles
- FEATURE** Rubber padded surface

CRASHERS, BACKBEAT TAMBOURINES & JINGLE STICKS



1 TURBO CRASHERS

SIZES **CRASHER-M**: Medium
CRASHER: Large

MATERIAL Steel

FEATURES Güiro style playing surface; Cutting sound; Easy mountable

2 BACKBEAT TAMBOURINES

SIZES **BBT1-BK**: For 10" and 12" drums
BBT2-BK: For 13" and 14" drums

MATERIALS Eco-friendly medium density fiberboard; Stainless steel jingles

FEATURES Fits on any standard drum; Adds a tambourine sound to the groove; Hook and loop fastener

COLOUR **BK**: Black

3 BACKBEAT PRO TAMBOURINE

SIZE 14"

MATERIALS Cymbal brass alloy ring; Solid brass jingles

FEATURES Blackened brass ring made from MEINL Cymbal Alloy; Eight pairs of solid brass jingles

4 HEADLINER® SERIES JINGLE STICKS

MATERIALS Molded ABS; Stainless steel jingles

COLOURS **BK**: Black
R: Red

5 PROFESSIONAL SERIES JINGLE STICKS

MATERIALS Molded ABS
JG1: Nickel plated steel jingles
JG1A: Aluminum jingles
JG1B: Solid brass jingles
JG1M: Nickel plated steel / solid brass jingles

FEATURES Padded grip; Güiro style playing surface

6 MULTI-JINGLE STICK

MATERIALS Molded ABS; Nickel plated steel / solid brass jingles

FEATURES Jingles mounted on two intersecting planes
Padded grip; Special playing techniques

ARTISAN EDITION RIQ DRUM & PANDEIROS



Synthetic head, 8 3/4"
AERIQ1



Clear Mylar head, 10"
PA10ABS-BK

CHROME PLATED STEEL JINGLES



Napa head, 10"
PA10ABS-BK-NH



Poplar Wood, 10"
PA10PW-M

CHROME PLATED STEEL JINGLES



Siam Oak, 10"
PA10CN-M



Goatskin head, 10"
PA10AB-M



Napa head, 10"
PAS10PW-NH



Siam Oak, 12"
PA12CN-M



Napa head, 10"
PA10A-BK-NH-H

7 ARTISAN EDITION RIQ DRUM
SIZE 8 3/4"
MATERIALS Wooden frame; Synthetic head;
 Ten pairs of brass jingles
FEATURES Artisan sounds for Arabic folk and
 classical music; Five tuning lugs
INCLUDES Tuning key; Bag
FINISH White Pearl Mosaic Royale

8 TRADITIONAL ABS PANDEIROS
SIZE 10"
MATERIALS Molded ABS; Chrome plated steel jingles
PA10ABS-BK
 Replaceable synthetic head
PA10ABS-BK-NH
 Replaceable Napa head
FEATURES Countersunk bolt lugs
PA10ABS-BK: Logo applied from under-
 neath the head (CN, TH, US patent)
PA10ABS-BK-NH: Reduced overtones

INCLUDES Tuning key
COLOUR **BK**: Black

9 TRADITIONAL WOOD PANDEIROS
SIZES **PA10**: 10"
PA12: 12"
MATERIALS Replaceable hand selected goatskin head;
 Chrome plated steel jingles
PA10CN-M, PA12CN-M
 Siam Oak (*Hevea brasiliensis* Muell.-Arg.)
PA10PW-M
 Poplar Wood (*Populus*)
INCLUDES Tuning key
COLOUR **CN-M**: Chestnut, matte

10 SHELL-TUNED PANDEIRO
SIZE 10"
MATERIALS Siam Oak (*Hevea brasiliensis* Muell.-Arg.)
 Hand selected goatskin head;
 Hand-hammered brass jingles

INCLUDES Hex key
COLOUR **AB-M**: Antique Brown, matte

11 SHAKER PANDEIRO
SIZE 10"
MATERIALS Poplar Wood (*Populus*); Replaceable
 Napa head; Aluminum shaker pods
FEATURE Countersunk bolt lugs
INCLUDES Tuning key

12 TRADITIONAL ABS PANDEIRO WITH HOLDER
SIZE 10"
MATERIALS Molded ABS; Replaceable Napa head;
 Chrome plated steel jingles
FEATURES Countersunk bolt lugs; Reduced overtones;
 Easy mountable
INCLUDES Tuning key
COLOUR **BK**: Black

ARTIST SERIES SHAKERS, PERC PACK, EGG SHAKERS,

1

<p>SOFT: STUDIO</p>  <p>Studio shaker, Red SH5R</p> <p>72 - 76 DB</p>	<p>MEDIUM: LIVE</p>  <p>Live shaker, Black SH4BK</p> <p>79 - 81 DB</p>	<p>MEDIUM: LIVE</p>  <p>Live shaker, Creamsicle SH4CS</p>	<p>MEDIUM: LIVE</p>  <p>Live shaker, Electric Coral SH4EC</p>
<p>MEDIUM: LIVE</p>  <p>Live shaker, Glacier Blue SH4GB</p>	<p>MEDIUM: LIVE</p>  <p>Live shaker, Seafoam Green SH4SF</p>	<p>MEDIUM: LIVE</p>  <p>Live shaker, White SH4WH</p>	<p>LOUD: STADIUM</p>  <p>Stadium shaker, Grey SH45GR</p> <p>88 - 93 DB</p>

2



MSS

3



Set, 3 pcs.
PP-1

4



Set, 4 pcs.
ES-SET-2

5

SOFT

MEDIUM

LOUD

EXTRA LOUD



Set, 4 pcs.
ES-SET

6

COMES IN A SET OF TWO

Black **ES2-BK**

Red **ES2-R**

Blue **ES2-B**

Yellow **ES2-Y**

Green **ES2-GREEN**



1 ARTIST SERIES SHAKERS LUIS CONTE

SIZE Medium

MATERIAL Synthetic

FEATURES Two individual shakers connected as one instrument

SH4: Perfect for live playing

SH45: Perfect for stadium situations

SH5: Perfect for studio recordings

COLOURS

BK: Black

CS: Creamsicle

EC: Electric Coral

GB: Glacier Blue

GR: Grey

R: Red

SF: Seafoam Green

WH: White

2 LUIS CONTE SHAKER WITH STRAPS

SIZE Medium

MATERIAL Synthetic

FEATURES Strap to a drumstick to get shaker sounds as you play

Add new sonic layers to your drum set grooves

COLOUR **BK:** Black

INCLUDES Two durable rubber straps

3 PERC PACK

CONTAINS Compact Foot Tambourine

Luis Conte Live Shaker

Classic Wood Claves

FEATURES Compact Foot Tambourine for hands free use

Luis Conte Live Shaker for smooth sound

Classic Wood Claves for traditional rhythms

4 EGG SHAKER ASSORTMENT

MATERIAL Synthetic

FEATURES Four-piece egg shaker set ideal for any percussion set up

Designed for four different volume levels

Colour coded for easy identification

Easily transportable

5 EGG SHAKER SET

MATERIAL Synthetic

FEATURE Range of volume from soft to extra loud

6 EGG SHAKER PAIRS

MATERIAL Synthetic

FEATURE Comes in a set of two

COLOURS

B: Blue

BK: Black

GREEN: Green

R: Red

Y: Yellow

FACE SHAKERS, KEY RING SHAKERS & TAMBOURINES



SHAKERS



Set, 24 pcs.
ES-SET24-BK

Set, 24 pcs.
ES-SET24-MC



Set, 60 pcs.
ES-BOX

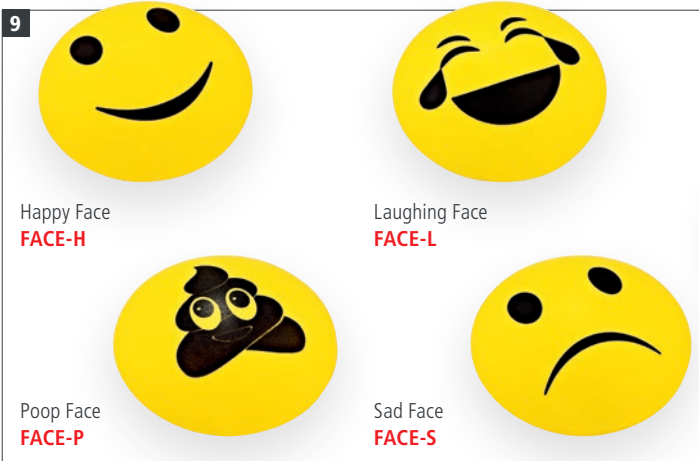

Happy Face
FACE-H

Laughing Face
FACE-L

Poop Face
FACE-P

Sad Face
FACE-S

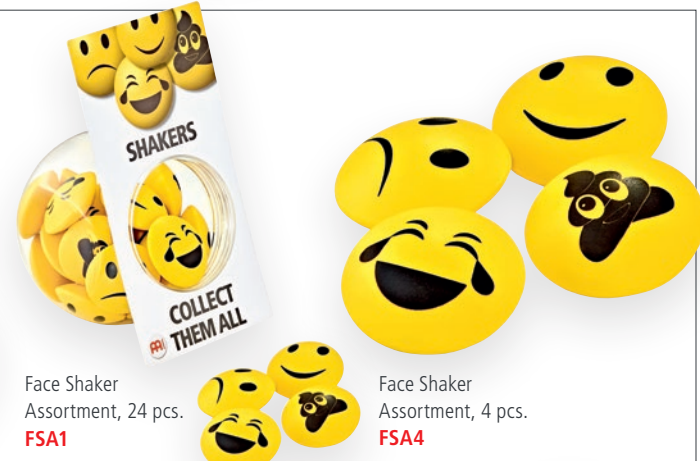

Face Shaker Assortment, 24 pcs.
FSA1

Face Shaker Assortment, 4 pcs.
FSA4



Key Ring Tambourine, red
KRT-R

Key Ring Tambourine, black
KRT-BK

Key Ring Shaker and Tambourine Assortment
KRA1

Key Ring Shaker, grey
KRS-GR

Key Ring Shaker, black
KRS-BK

7 EGG SHAKER SETS OF 24 PCS.

- MATERIAL** Synthetic
- FEATURES** Crystal clear shaker sounds
Durable shells
Great for group or classroom percussion
- COLOURS** **BK:** Black
MC: Multi-colour

8 EGG SHAKER BOX

- CONTAINS** Holds 60 Egg Shakers:
20 x Egg Shaker, Blue (B)
10 x Egg Shaker, Black (BK)
10 x Egg Shaker, Green (GREEN)
10 x Egg Shaker, Red (R)
10 x Egg Shaker, Yellow (Y)

9 FACE SHAKERS

- MATERIAL** Molded ABS
- CONTAINS** **FSA1**
6 x Happy Face
6 x Laughing Face
6 x Poop Face
6 x Sad Face
FSA4
1 x Happy Face
1 x Laughing Face
1 x Poop Face
1 x Sad Face
- FEATURES** Made of durable molded ABS
Loud filling projects clearly
Great accent for live and studio applications
- INCLUDES** **FSA1:** Fishbowl

- GRAPHICS** **FACE-H:** Happy Face
FACE-L: Laughing Face
FACE-P: Poop Face
FACE-S: Sad Face

10 KEY RING SHAKERS & KEY RING TAMBOURINES

- MATERIALS** Molded ABS
KRT: Nickel plated steel
- CONTAINS** **KRA1**
10 x Key Ring Shaker
8 x Key Ring Tambourine
- FEATURES** Easily detach when it's time to play
Perfect for acoustic shows or jam sessions
- INCLUDES** **KRA1:** Fishbowl
- FINISHES** **BK:** Black
GR: Grey
R: Red

SYNTHETIC, FIBERGLASS & ALUMINUM SHAKERS

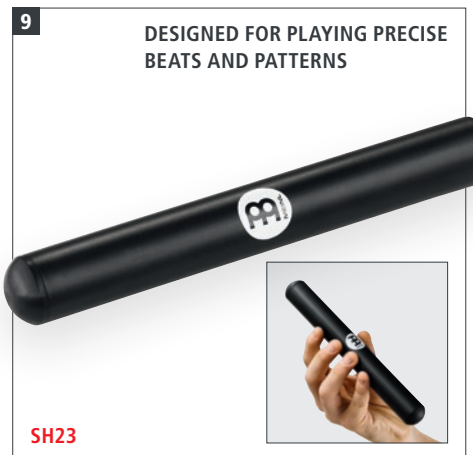
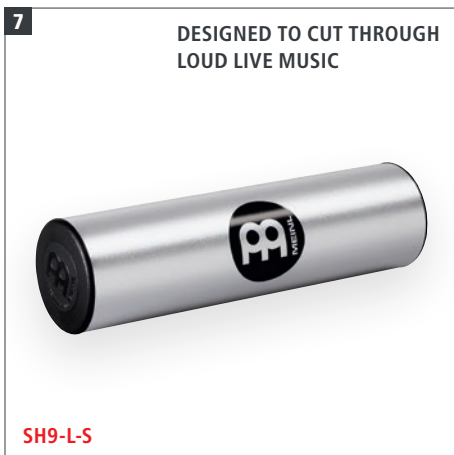
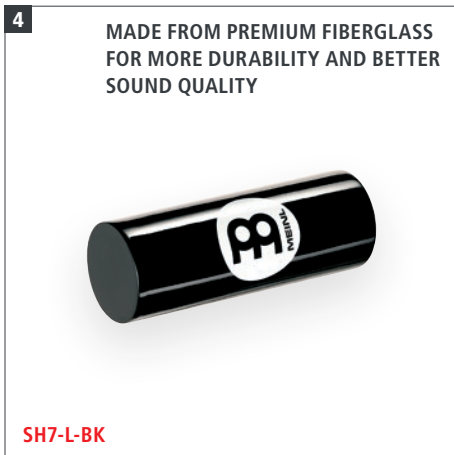

1 STUDIO SHAKERS

SIZES **SH10-M-BK**: Medium
SH10-L-BK: Large

MATERIAL Synthetic

FEATURE Deliver a very tasteful and delicate shaker sound with a warm tone and well balanced frequency spectrum

COLOUR **BK**: Black

2 STUDIOMIX SHAKERS

SIZES **SH12-M-BK**: Medium
SH12-L-BK: Large

MATERIAL Synthetic

FEATURE Textured surface for special sound and positive grip

COLOUR **BK**: Black

3 CRYSTAL SHAKERS

SIZE Large

MATERIALS Synthetic; Acrylic

FEATURES Shapes any groove with clarity and feel
SH26-L-L: Perfect for live playing
SH26-L-S: Perfect for studio recordings

4 FIBERGLASS SHAKER

SIZE Large

MATERIAL Premium fiberglass

FEATURE Made from premium fiberglass for more durability and better sound quality

COLOUR **BK**: Black

5 ALUMINUM SHAKERS, OCTAGONAL

SIZES **SH8BK**: Small
SH88BK: Medium
SH888BK: Large

MATERIAL Aluminum

FEATURE Provides a broad dynamic range with lots of volume

COLOUR **BK**: Black

6 ALUMINUM JINGLE SHAKER

SIZE Medium

MATERIALS Shaker: Aluminum
Jingles: Steel

FEATURE Two pairs of steel jingles are attached in one row to an octagonal aluminum shaker

COLOUR **BK**: Black

7 ALUMINUM SHAKER, ROUND

SIZE Large

MATERIAL Anodized aluminum

FEATURE Designed to cut through loud live music

COLOUR **S**: Silver

8 PROJECTION SHAKER

SIZE Large

MATERIAL Anodized aluminum

FEATURES For comfort and volume; Shimmering, cutting pitch; Exceptional for live playing

COLOUR **S**: Silver

SPARK & SYNTHETIC SHAKERS



10 CIRCULAR MOTION ENABLES A UNIQUE RATTLING



Spark shaker
SH16

SENSATIONAL EFFECTS ARE PRODUCED WHEN COMBINED WITH ANOTHER SPARK SHAKER



11 SCREW-MOUNTED DISC ENABLES A TUNABLE PITCH



Spin spark
SH17

12



Headed spark
SH18

MOTION SHAKER
(SEE PAGE 49)



MS-BK

13



Medium
SH20BK

BY COVERING AND UNCOVERING THE SOUND HOLE, A "WAH-WAH" EFFECT CAN BE ACHIEVED

14 LOUD AND PENETRATING SOUND DUE TO THE MANY HOLES



SH3BK

15



Black
SH21BK

9 PROTON SHAKER
MATERIAL Aluminum
FEATURES Compact size; Easy to control; Made for precise playing techniques

10 ORIGINAL SPARK SHAKER
SIZE Medium
MATERIALS Shaker: Coated steel
 Pellets: Coated steel
FEATURES Circular motion enables a unique rattling; Spark Shakers may be played in pairs
FINISH Black nickel

11 SPIN SPARK SHAKER
SIZE Medium
MATERIALS Shaker: Coated steel
 Pellets: Coated steel
FEATURE Screw-mounted disc enables a tunable pitch
FINISH Black nickel

12 HEADED SPARK SHAKER
SIZE Medium
MATERIALS Shaker: Coated steel
 Pellets: Coated steel
 Goatskin head
FEATURES Premium goatskin and a steel shell provide a rattling combination; Swirling effect; Variable pitch
FINISH Black nickel

13 WAKAH SHAKER
SIZE Medium
MATERIALS Wooden body and synthetic chamber
FEATURE By covering and uncovering the sound hole, a "wah-wah" effect can be achieved
COLOUR **BK**: Black

14 LOOP SHAKER
SIZE Medium
MATERIAL Synthetic
FEATURE Loud and penetrating sound due to the many holes
COLOUR **BK**: Black

15 U.F.O. SHAKER
SIZE Medium
MATERIAL Synthetic
COLOUR **BK**: Black

WOOD SHAKERS, DOUBLE SHAKER, GANZA & CAXIXIS



1 MINI CAJON SHAKERS

SIZE 2" W x 2 3/4" H x 2" D
MATERIALS Resonating body: Baltic Birch (*Betula pendula*)
SH50
 Frontplate: Baltic Birch (*Betula pendula*)
SH51
 Frontplate: Ovangkol (*Guibourtia ehie*)
FEATURES Compact size; Cutting shaker sound; Miniature size of a MEINL cajon

2 MINI CAJON SHAKER SET

MATERIALS Resonating body: Baltic Birch (*Betula pendula*)
 Frontplates: Exotic Zebrano, Burl Wood, Baltic Birch (*Betula pendula*)
FEATURES Three unique timbres for multiple sound options; Various frontplates for easy identification

3 WOOD SHAKERS, RECTANGLE

SIZES **S:** Small
M: Medium
MATERIALS Baltic Birch (*Betula pendula*)
 Top and Bottom: Exotic Zebrano
FEATURES Wide sound options; Rectangle shaped

4 DUAL CHAMBER SHAKER

MATERIAL Baltic Birch Plywood (*Betula pendula*)
 Top and Bottom: Burl Wood
FEATURES Dual internal chambers for greater shaker control; Easier to play consistent shaker patterns; Ultra-smooth sound

5 WOOD SHAKERS, ROUND

SIZE 4" length, 1 3/4" diameter
MATERIALS **SH56:** Lime
SH58: Beech
SH59: Oak

FEATURES Made from three wood species for different volume; Fits comfortably in your hand
SH56: Soft
SH58: Medium
SH59: Loud

6 DOUBLE SHAKER & GANZA

MATERIALS Rattan with coconut bottom
FEATURES **D01:** Offers two different sounds in one instrument
GA2: Crystal clear sound, high pitched with a great projection

7 CAXIXIS

SIZES **CAX1:** Small
CAX2: Medium
CAX3: Large
MATERIALS Rattan with coconut bottom
FEATURES Crystal clear sound, high pitched with a great projection; Woven by hand

MARACAS



SHAKERS & MARACAS

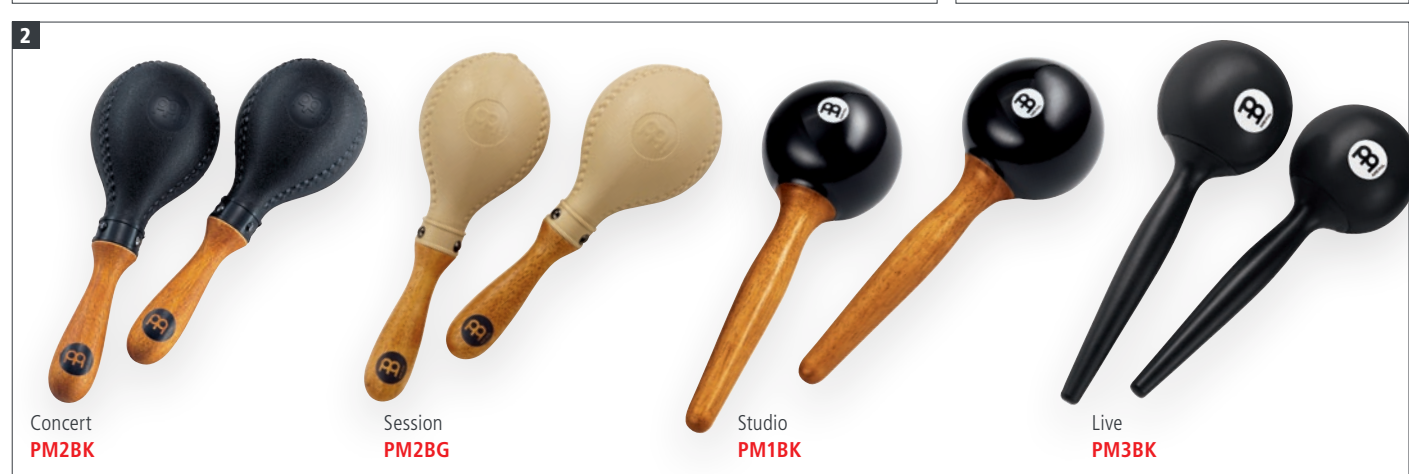
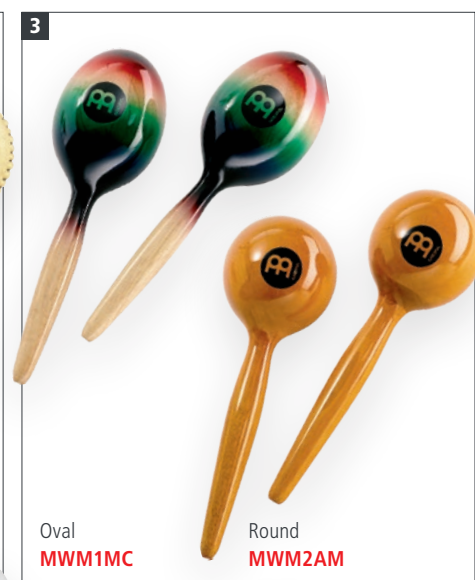

1 RAWHIDE MARACAS

SIZES **MSM2:** Mini
MSM3: Traditional
MSM4: Jumbo

MATERIALS Natural rawhide and wooden handle

FEATURES Entirely made by hand
Offers a wide sonic range
Durable construction

DESIGNS **CO:** Colombia flag
CU: Cuba flag
MX: Mexico flag

2 CONCERT, SESSION, STUDIO & LIVE MARACAS

MATERIAL Synthetic heads

FEATURE Ergonomically shaped handle

COLOURS **BG:** Beige
BK: Black

3 WOOD MARACAS

MATERIAL Wood

FEATURES Produces a traditional warm and rich sound
Available in both round and oval models

4 PLASTIC EGG MARACAS

SIZE 6"

MATERIAL Synthetic

FEATURE Ergonomically shaped handle



COWBELLS

1 BLACK POWDER COATED STEEL

8" **HCO2BK**
5" **HCO4BK**

2 BLACK POWDER COATED STEEL

8 1/2" **SL850-BK**
6 3/4" **SL675-BK**
5 1/4" **SL525-BK**
4 3/4" **SL475-BK**

3 EASY MOUNTABLE

2 1/2", 3 1/2", 5"
SLTRI-BK

4 CLASSIC ROCK COWBELL

7" big mouth, low pitch **SCL70B-BK**
8 1/2" low pitch **SCL850-BK**
7" high pitch **SCL70-BK**

TIMBALERO COWBELLS

7" big mouth, low pitch **SCL70B-BK**
8 1/2" low pitch **SCL850-BK**
7" high pitch **SCL70-BK**

HANDMATE (SEE PAGE 89)

HAM1BK

5 HIGH POLISHED CHROME

8" big mouth **STB80B-CH**
8" small mouth **STB80S-CH**
7 1/2" **STB750-CH**
6 1/4" **STB625-CH**
5 1/2" **STB55-CH**
4 1/2" low pitch **STB45L-CH**

HAND BRUSHED STEEL

8" big mouth **STB80B**
8" small mouth **STB80S**
6 1/4" **STB625**
5 1/2" **STB55**
4 1/2" low pitch **STB45L**
4 1/2" medium pitch **STB45M**
4 1/2" high pitch **STB45H**

COWBELLS 1 – 11

MATERIAL Special steel alloy

1 HEADLINER® SERIES COWBELLS

SIZES **HCO2BK**: 8" (Timbales Cowbell)
HCO4BK: 5" (Cha Cha Cowbell)

FEATURE Muffled sound

FINISH **BK**: Black powder coated

2 BLACK FINISH COWBELLS

SIZES **SL850-BK**: 8 1/2" (Timbales Cowbell)
SL675-BK: 6 3/4" (Medium Timbales Cowbell)
SL525-BK: 5 1/4" (Cha Cha Cowbell)
SL475-BK: 4 3/4" (Mini Cha Cha Cowbell)

FEATURE Muffled sound

FINISH **BK**: Black powder coated

3 TRIPLE BELL

SIZES 2 1/2", 3 1/2", 5"

FEATURE Muffled sound

FINISH **BK**: Black powder coated

4 STEEL CRAFT LINE COWBELLS

SIZES **SCL70B-BK**: 7" (Classic Rock Cowbell Big Mouth)
SCL850-BK: 8 1/2" (Timbalero Cowbell)
SCL70-BK: 7" (Timbalero Cowbell)

FEATURES Steel alloy controls overtones and resonance; Classic cowbell sound for any setting

FINISH **BK**: Black powder coated

5 CHROME & STEEL FINISH COWBELLS

SIZES **STB80B**: 8" (Timbales Cowbell Big Mouth)
STB80S: 8" (Timbales Cowbell Small Mouth)
STB750: 7 1/2" (Salsa Timbales Cowbell)

STB625: 6 1/4" (Medium Timbales Cowbell)

STB55: 5 1/2" (Cha Cha Cowbell)

STB45L: 4 1/2" (Low Cha Cha Cowbell)

STB45M: 4 1/2" (Medium Cha Cha Cowbell)

STB45H: 4 1/2" (High Cha Cha Cowbell)

FEATURE Tonally matched

FINISHES Hand brushed steel

CH: High polished chrome

6 HAMMERED COWBELLS

SIZES **STB80BHH**: 8" (Timbales Cowbell Big Mouth)

STB625HH: 6 1/4" (Medium Timbales Cowbell)

FEATURE Hammered

FINISHES **C**: Hand brushed copper

G: Hand brushed gold

S: Hand brushed steel

6 HAND BRUSHED GOLD 8" big mouth STB80BHH-G	 HAND BRUSHED STEEL 8" big mouth STB80BHH-S	 HAND BRUSHED COPPER 8" big mouth STB80BHH-C
 6 1/4" STB625HH-G	 6 1/4" STB625HH-S	 6 1/4" STB625HH-C

7

DEMO VIDEO
GROOVE BELL DESIGNED WITH MIKE JOHNSTON
 7 3/4"
MJ-GB
8

BLACK POWDER COATED STEEL
 8"
BCOB
9
SPECIAL STEEL ALLOY

 8 1/4" **STB815H** 7 3/4" **STB785H** 6 1/2" **STB65H**
10

 8"
VR-HCB-R
11
COMFORTABLE HOLDER

 6 1/4" **STB625HA-CB** 4 1/2" **STB45HA-CB**
12

Magnetic Sustain Control MCT
BASED ON BENNY GREB'S IDEA
13

Drum Honey Slab MDHS
14
A DROP OF HONEY MAKES YOUR DRUMS AND CYMBALS SOUND SWEET

Drum Honey MDH **Drum Honey Assortment MDHA**
15

Medium MPCC-M **Large MPCC-L**
7 ARTIST SERIES COWBELL MIKE JOHNSTON

SIZE 7 3/4"
FEATURES Specifically made for drum set use
INCLUDES Two magnets (one small and one large, based on Benny Greb's Magnetic Sustain Control idea)
FINISH Vintage Steel

8 BONGO COWBELL

SIZE 8" (Medium Handheld Cowbell)
FEATURES Muffled sound; For low volume playing
FINISH Black powder coated

9 HAND COWBELLS

SIZES **STB815H:** 8 1/4" (High Handheld Cowbell)
STB785H: 7 3/4" (Low Handheld Cowbell)
STB65H: 6 1/2" (Mini Handheld Cowbell)
FINISH Hand brushed steel

10 HAND COWBELL

SIZE 8"
MATERIALS Powder coated steel
 Molded ABS
FEATURES Muffled, firm sound; Handheld; Rich tones
INCLUDES Cowbell beater with ribbed grip
COLOUR Red

11 HANDHELD COWBELLS

SIZES **STB625HA-CB:** 6 1/4"
STB45HA-CB: 4 1/2"
FEATURE Comfortable holder
FINISH Hand brushed steel

12 MAGNETIC SUSTAIN CONTROL

CONTAINS 2 x Light dampening magnets (16 x 4 mm)
 2 x Heavy dampening magnets (16 x 9 mm)
FEATURE Easily control the sustain and dampen the tone of your cymbals or cowbells
INCLUDES Storage container

13 DRUM HONEY SLAB

SIZE 3.54" x 2.36" x 0.31"
FEATURES Extra thick rectangular dampening gel pad; Creates a super meaty drum tone

14 DRUM HONEY

CONTAINS **MDH:** 1 pack of Drum Honey (6 pcs.)
MDHA: 12-piece Drum Honey Assortment (6 x small, 4 x medium, 2 x large)
FEATURES Transforms your drum sound into a warm and sweet tone with no effort; The gels can be removed and reused as needed; Washable and non-toxic

15 COWBELL CUSHIONS

SIZES **MPCC-M:** Medium (32 grams)
MPCC-L: Large (70 grams)
FEATURES Instantly turn your cowbell sound into a retro, super-dry effect; No adhesive material required

BLOCKS, TEMPLE BLOCK SETS & GÜIROS



1 PERCUSSION BLOCKS

MATERIAL PE

FEATURES Ultra-durable plastic
MPE5NG: High pitched sound
MPE3BK: Medium pitched sound
MPE4R: Low pitched sound

INCLUDES Mounting Clamp

COLOURS **BK**: Black
NG: Neon Green
R: Red

2 SYNTHETIC TEMPLE BLOCK SET

MATERIAL PE

FEATURES 5-piece set of durable synthetic percussion blocks; Varying pitch from high (smallest block) to low (largest block); Hollow body design produces a rich percussion block tone; Metal frame with adjustable thumb screw mount

INCLUDES Mounting Clamp; Beater

COLOUR Black

3 WOOD TEMPLE BLOCK SET

MATERIAL Baltic Birch (*Betula pendula*)

FEATURES 5-piece tonally matched wood temple block set; 100% Baltic birch construction for natural wood tone; Rear mount fits any standard drum hardware; Tuning from low to high: D5, F5, A5, C6, D6

INCLUDES Two soft rubber head mallets

4 WOOD TEMPLE BLOCKS

MATERIAL Baltic Birch (*Betula pendula*)

TUNING **TMWB-XS**: D6
TMWB-S: C6
TMWB-L: F5

FEATURES Natural wood tone; Fits a variety of musical situations

INCLUDES Wood block holder

5 WOOD BLOCK HAND CLAP

MATERIAL Baltic Birch (*Betula pendula*)

FEATURES Combination wood block and hand clap effect; Baltic birch construction with steel cabasa chain; Padded surface to play with drumsticks

6 PROFESSIONAL WOOD BLOCKS

SIZES **M**: Medium
L: Large

MATERIALS Select Hardwood top
Siam Oak body
(*Hevea brasiliensis* Muell.-Arg.)

FEATURES Well defined fundamental sound; Detailed with heat-branded logo

INCLUDES Wooden beater

7 WOOD BLOCKS

SIZES **MWB1BK**: Medium
MWB2BK: Large

CASTANETS & CLAVES



HAND PERCUSSION



11 SEPARATELY ADJUSTABLE
CM2

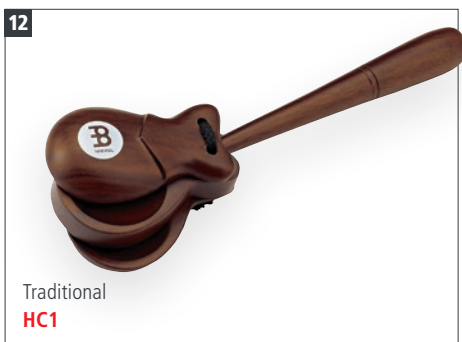

12 Traditional
HC1

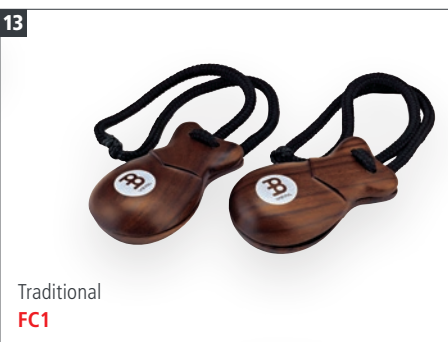

13 Traditional
FC1



Concert
FC2

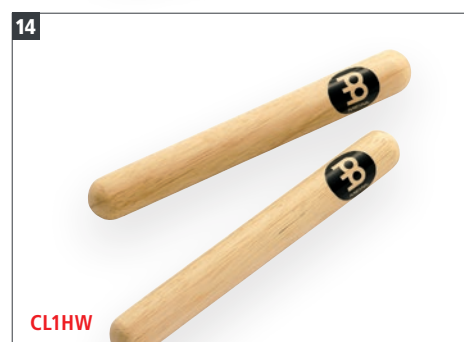

14
CL1HW



CL1RW



15
CL2HW

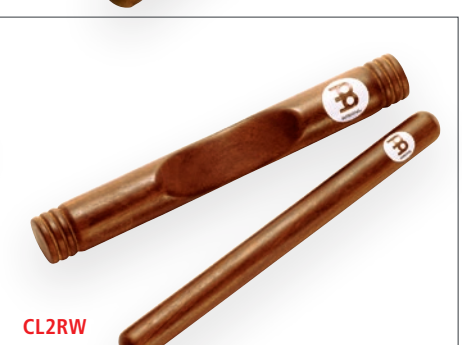

CL2RW



16 NEW
CL4IW



CL3HW



CL3RW

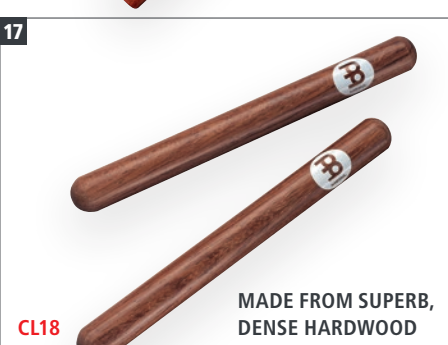

17
CL18 MADE FROM SUPERB, DENSE HARDWOOD

MATERIAL Siam Oak (*Hevea brasiliensis* Muell.-Arg.)
FEATURE Rounded playing surface
INCLUDES Wooden beater
COLOUR **BK**: Black, matte

8 TURBO GÜIRO
MATERIAL High strength plastic
FEATURES Three striking surfaces; Rubber ringed grip holes
INCLUDES Synthetic scraper

9 FIBERGLASS GÜIROS
MATERIAL Premium fiberglass
FEATURES Three striking surfaces; Padded grip holes
INCLUDES **GU7BK**: Synthetic scraper
GU7BR: Wooden scraper
COLOURS **BK**: Black
BR: Brown

10 WOOD GÜIRO
MATERIAL Wood
FEATURE Grip holes
INCLUDES Wooden scraper
COLOUR **AM**: Amber

11 CASTANET MACHINE
SIZE 7 1/2" x 5"
MATERIAL Indian Rosewood
FEATURES Separately adjustable; Full and cutting resonance

12 TRADITIONAL HAND CASTANET
SIZE Traditional
MATERIAL Indian Rosewood

13 FINGER CASTANETS
SIZES **FC1**: Traditional
FC2: Concert
MATERIAL Indian Rosewood

14 WOOD CLAVES, CLASSIC
MATERIALS **HW**: Hardwood
RW: Select Hardwood
FEATURE Solid body



15 WOOD CLAVES, AFRICAN
MATERIALS **HW**: Hardwood
RW: Select Hardwood
FEATURES **CL2**: Solid body
CL3: HOLLOWED OUT BODY

16 WOOD CLAVES, TRADITIONAL
SIZE 8" long and 1" diameter
MATERIAL **IW**: Indian Walnut
FEATURES Classic pitch and clear, piercing attack

17 CLAVES DE LUXE
SIZE 6 3/4" long
MATERIAL Dense hardwood
FEATURES Cutting sound; Convenient carrying

CABASAS, SLEIGH BELLS & KALIMBAS

1 PORTS FOR MORE VOLUME (PATENTED)

X-Small
PCA5BK-XS



Small
CA5BK-S



Medium
CA5BK



Large
CA5BK-L

2 ADJUSTABLE NET FOR VARIOUS TENSIONS AND SOUND OPTIONS



CA7BR

3 STEEL BELLS

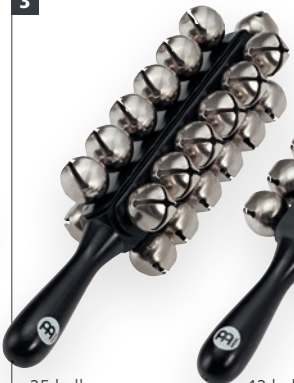

25 bells
SLB25



12 bells
SLB12



7 bells
SLB7

4



Small
KA5-S



Medium
KA7-M-BK



Medium
KA9-M

5 WIDE OPENING FOR GREAT WAH-WAH EFFECTS



KA9WW-BK

6 NEW



Coral Reef
KA17CR



Lava
KA17LV



Sun
KA17SU



7 NEW BUILT-IN PICKUP



PKA17AW

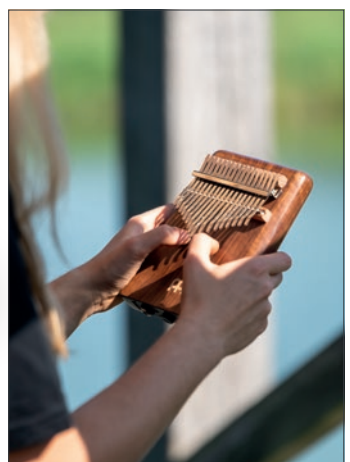

1 TURBO CABASAS (PATENTED)

SIZES **PCA5BK-XS**: X-Small; **CA5BK-S**: Small
CA5BK: Medium; **CA5BK-L**: Large

MATERIALS Steel chain and stainless steel cylinder
CA: Wooden handle with padded soft grip
PCA: Synthetic grip

FEATURE 5 sound ports on each side for more volume (CN, US patent)

COLOUR **BK**: Black

2 CABASA, FIBERGLASS

MATERIAL Premium fiberglass

COLOUR **BR**: Brown

3 SLEIGH BELLS

SIZES **SLB7**: 7 bells; **SLB12**: 12 bells;
SLB25: 25 bells

MATERIALS Steel bells; Wooden handle

FEATURES Ergonomic grip; True sleigh bell sound

4 SOLID KALIMBAS

SIZES **KA5-S**: Small
KA7-M-BK, **KA9-M**: Medium

MATERIALS New Zealand Pine (*Pinus radiata*)

TUNING **KA5-S**: g#, c', f', c''
KA7-M-BK: e', g, d'', e, c', a, a'
KA9-M: a', c', c', a, A, f', e', e'', b'

FEATURES **KA5-S**, **KA9-M**: Heat-branded logo
KA7-M-BK: Extra wide tongues

5 WAH-WAH KALIMBA

MATERIALS New Zealand Pine (*Pinus radiata*)

TUNING a', c', c', a, A, f', e', e'', b'

COLOUR **BK**: Black

6 SOUND HOLE DESIGNER KALIMBAS

MATERIALS **KA17CR**, **KA17LV**: Acacia
KA17SU: Sapele

TUNING C Major: d'', b', g', e', c', a, f, d, c, e, g, b, d', f', a', c'', e'' (17 notes)

FEATURES Easy for all skill levels

INCLUDES Travel case; Microfiber cleaning cloth; Tuning hammer

DESIGNS **CR**: Coral Reef; **LV**: Lava; **SU**: Sun

7 SOLID PICKUP KALIMBA

MATERIALS American Walnut

TUNING C Major: d'', b', g', e', c', a, f, d, c, e, g, b, d', f', a', c'', e'' (17 notes)

FEATURES Easy for all skill levels; Built-in pickup

INCLUDES Travel case; Microfiber cleaning cloth; Tuning hammer

WHISTLE, GÜIRAS, ROCARS, SHAKERS & A-GO-GOS



HAND PERCUSSION



SW-1



X-Small
MGU4

Small
MGU3

Medium
MGU2

Large
MGU1

COME WITH SCRAPER



MGU51



Medium
RC2-M

Large
RC2-L



Small Single
SSH1-S

Medium Single
SSH1-M

Large Single
SSH1-L

Small Double
SSH2-S

Medium Double
SSH2-M

Large Double
SSH2-L



Small
STBAG5

Small
STBAG1

Large
STBAG2



Small
STBAG4-CH

Large
STBAG2-CH



Medium
STBAG3-CH



Medium
STBAGTRI-CH

TONALLY MATCHED

1 SAMBA WHISTLE

MATERIAL Aluminum
INCLUDES Neck lanyard

2 MERENGUE GÜIRAS

SIZES **MGU4**: X-Small; **MGU3**: Small; **MGU2**: Medium; **MGU1**: Large

MATERIAL Brushed steel
FEATURES Scraping surface with uniform raised bumps; One-piece metal grip with welded flanges

INCLUDES ABS scraper MGS2

3 MERENGUE GÜIRA SHAKER

MATERIAL Brushed steel
FEATURES Filling inside to produce a cutting shaker effect; Scraping surface with uniform raised bumps; One-piece metal grip with welded flanges
INCLUDES ABS scraper MGS2

4 ALUMINUM ROCARS

SIZES **RC2-M**: Medium; **RC2-L**: Large

MATERIAL Aluminum frame and jingles
FEATURES Light weight frame; Loud projection

5 ALUMINUM SAMBA SHAKERS

SIZES **S**: Small; **M**: Medium; **L**: Large

MATERIAL Aluminum
FEATURE Produces warm and cutting shaker sound

6 MODERN STYLE A-GO-GO STEEL FINISH MODELS

SIZES **STBAG1, STBAG5**: Small
STBAG2: Large

MATERIAL Special steel alloy
FEATURE Tonally matched
FINISHES **STBAG1, STBAG2**: Hand brushed steel
STBAG5: Black powder coating

7 MODERN STYLE A-GO-GO CHROME FINISH MODELS

SIZES **STBAG4**: Small; **STBAG2**: Large

MATERIAL Special steel alloy
FEATURES Flexible connection; Bright sound
FINISH High polished chrome

8 TRADITIONAL STYLE A-GO-GO BELL

SIZE Medium
MATERIAL Special steel alloy
FEATURES Traditional shape; Flexible connection
FINISH High polished chrome

9 TRIPLE A-GO-GO BELL

SIZE Medium
MATERIAL Chrome plated steel
FEATURES Traditional Shape; Three tonally matched bells in equal intervals; Spring handle enables counterpoint rhythms

SOUND EFFECTS

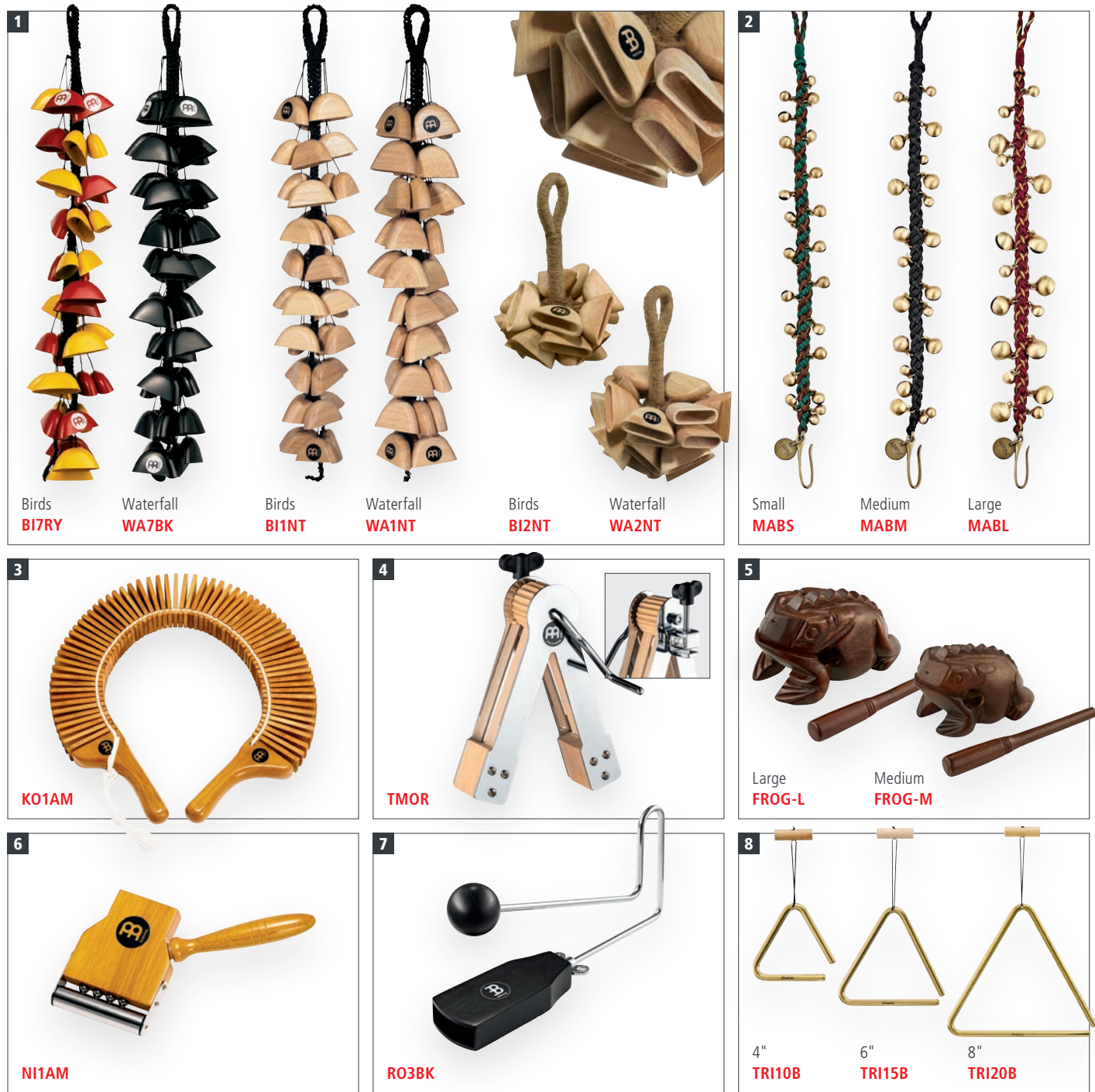

1 BIRDS & WATERFALLS

MATERIALS **B17RY, WA7BK:** Premium fiberglass
B11NT, WA1NT, B12NT, WA2NT: Siam Oak (*Hevea brasiliensis* Muell.-Arg.)
FEATURES Durable cord
BI: Realistically imitate the sound of a flock of birds; Bright sound with big dynamic range
WA: Realistically imitate the sound of a rippling waterfall
COLOURS **BK:** Black
NT: Natural
RY: Red/Yellow

2 AJUCH BELLS

SIZES 30" long
MABS: Small bells
MABM: Medium bells
MABL: Large bells
MATERIAL Brass and synthetic wax

FEATURES Cast bells; Solid hook for easy attachment; Synthetic wax rope
INCLUDES Canvas pouch for safe and simple storage
COLOURS **MABS:** Brown and Turquoise
MABM: Black
MABL: Dark Red and Gold

3 KOKIRIKO

MATERIAL Wood
FEATURES Ergonomically shaped handle; Durable cord
COLOUR **AM:** Amber

4 ORCHESTRA RATCHET

MATERIALS Chrome plated steel
Hood Pine Tines
FEATURES Produce quick notes like a cabasa or long-sustaining rattle effects; Wooden internal paddles project clearly; Easy to grip metal hand crank; Mountable on a stand

5 WOODEN FROGS

SIZES **M:** Medium; **L:** Large
FEATURE Authentic "ribbit" sound

6 THE NIGHT

MATERIALS Solid steel balls and cylinder
Wooden body
COLOUR **AM:** Amber

7 THE ROAR

MATERIAL Wood
FEATURE Rattling sustain

8 TRIANGLES

SIZES **TRI10B:** 4"
TRI15B: 6"
TRI20B: 8"
MATERIAL Solid brass
INCLUDES Wooden holder with braided nylon cord
Metal beater



27 bells
BT27



14 bells
BT14



FICY-14

SPECIAL BRONZE ALLOY

SOUND EFFECTS



PFICY-2



FICY-2

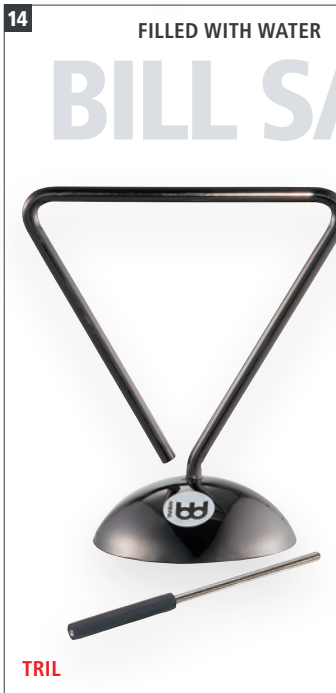

TRIL

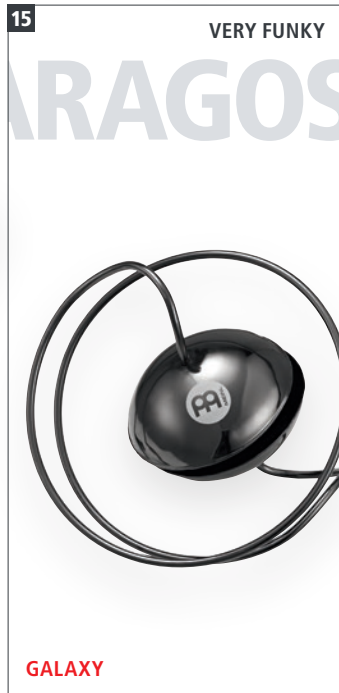

GALAXY



BOWL



RB85



WW2BK

9 STAND ALONE BELL TREE

MATERIAL Solid brass bells
FEATURE Adjustable metal stand
INCLUDES Striker

10 HAND HELD BELL TREE

MATERIAL Solid brass bells
INCLUDES Striker

11 HANGING FINGER CYMBALS

SIZES 2 3/8" diameter
MATERIAL Special bronze alloy
FEATURES Shimmering sound; Durable cord

12 PROFESSIONAL FINGER CYMBALS

SIZE 2 5/8" diameter
MATERIAL Special bronze alloy
FEATURES Identical, high pitched sound; Durable cord

13 ORIENTAL FINGER CYMBALS

SIZE 2 3/8" diameter
MATERIAL Special bronze alloy

BILL SARAGOSA LINE 14 15 16

MATERIAL Special steel alloy
FEATURE Wide sound spectrum
FINISH Black nickel

14 LIQUID TRIANGLE

FEATURES Special steel alloy, filled with water
INCLUDES Metal beater

15 GALAXY

FEATURES Two resonant liquid chambers are connected by a long steel spiral liquid; Inside the two chambers exerts variable dampening on the steel resonator plates
INCLUDES Metal beater

16 HELIX BOWL

FEATURES Wonderful instrument consisting of a steel helix welded to a resonating chamber; Deep resonating wah-wah effect
INCLUDES Metal beater

17 RHYTHM BELL

SIZE 8 1/2"
MATERIAL Special cast alloy
FEATURES Cutting bell sound; Very long sustain

18 WAH-WAH TUBE

SIZE Large (low pitch)
MATERIAL Aluminum
INCLUDES Rubber mallet
COLOUR **BK:** Black

DIDGERIDOOS

1 COLOURFUL HAND-PAINTED ACCENTS HARKEN TO TRADITIONAL NATIVE AUSTRALIAN DESIGNS

47" **DDG1-BK** 47" **DDG1-BR** 47" **DDG1-R**

2

51" **SDDG1-BK** S-Shape, 51" **SDDG2-BK**

3 TWO TELESCOPING SECTIONS

36"-62" **TSDDG1-BK**

<p>1 WOOD DIDGERIDOOS</p> <p>SIZE 47"</p> <p>MATERIAL Bamboo</p> <p>TUNING DDG1-BK: E DDG1-BR: D# DDG1-R: E</p> <p>COLOURS BK: Black BR: Brown R: Red</p>	<p>2 SYNTHETIC DIDGERIDOOS</p> <p>SIZE 51"</p> <p>MATERIAL Lightweight synthetic</p> <p>TUNING SDDG1-BK: D SDDG2-BK: C#</p> <p>FEATURES SDDG2-BK "S" shaped body for bigger sounds Distinctive, full drone and harmonic overtones</p> <p>COLOUR BK: Black</p>	<p>3 TROMBONE DIDGERIDOO</p> <p>SIZE 36"-62"</p> <p>MATERIAL Premium fiberglass</p> <p>TUNING from: G#, G, F#, F, E, D#, D, C#, C</p> <p>FEATURE Two telescoping sections for variable pitch</p> <p>COLOUR BK: Black</p>
----------------------------------------------------------------------------------------------------------------------------------------------------------------------------------------------------------------------------	--------------------------------------------------------------------------------------------------------------------------------------------------------------------------------------------------------------------------------------------------------------------------------------------------------------	----------------------------------------------------------------------------------------------------------------------------------------------------------------------------------------------------------------------------------------



60"
TSDDG2-BK



57"
PROFDDG1-BK



57"
PROSDDG1-BK



61"
SDDG1-SI



8 1/2" x 5"
DDG-BOX



9
100% PURE BEESWAX

DDG-MP

SMALL IN SIZE BUT BIG IN SOUND

DIDGERIDOOS

4 SYNTHETIC SLIDE TRAVEL DIDGERIDOO

SIZE Portable: 24"; Playable: 60"
MATERIAL Lightweight synthetic
TUNING D
FEATURES Contractible body for easy travel
Distinctive, full drone and harmonic overtones
INCLUDES Bag
COLOUR **BK:** Black

5 PRO FIBERGLASS DIDGERIDOO

SIZE 57"
MATERIAL Premium fiberglass
TUNING D
COLOUR **BK:** Black

6 PRO SYNTHETIC DIDGERIDOO

SIZE 57"
MATERIAL Lightweight synthetic
TUNING D
COLOUR **BK:** Black

7 ARTIST SERIES DIDGERIDOO SIMON "SI" MULLUMBY

SIZE 61"
MATERIAL Premium fiberglass
TUNING F
COLOUR Grey

8 TRAVEL DIDGERIDOO (US PATENT)

SIZE 8 1/2" x 5"
MATERIAL Mahogany Wood (*Swietenia macrophylla*)
TUNING C
FEATURES Heat-branded logo
Compact size

9 DIDGERIDOO MOUTHPIECE

SIZE Inner diameter: 30 mm
Outer diameter: 60 mm
MATERIAL Antiseptic beeswax
FEATURES Easy mountable
100% pure beeswax
Fits perfect on our didgeridoos

RAINSTICKS & RAINMAKER

1

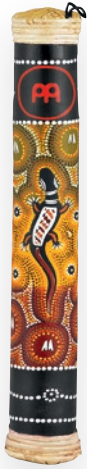

16"
RS1BK-S

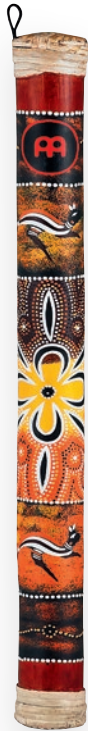

24"
RS1R-M



31 1/2"
RS1BK-M/L

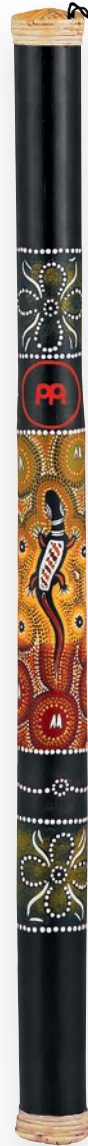

39"
RS1BK-L



47"
RS1BK-XL



60"
RS1BK-XXL



1 WOOD RAINSTICKS

SIZES
S: 16"
M: 24"
M/L: 31 1/2"
L: 39"
XL: 47"
XXL: 60"
 MATERIAL Bamboo
 COLOURS **BK:** Black
R: Red

2 SYNTHETIC RAINSTICK

SIZE **L:** 39"
 MATERIAL Lightweight synthetic
 COLOUR **R:** Red

3 PRO RAINSTICK

SIZE **XL:** 47"
 MATERIAL Rattan wrapped Bamboo
 FEATURES Long susuration
 Authentic rain sounds

4 PRO RAINMAKER

SIZE 3 3/4" W x 25 1/4" H x 3 3/4" D
 MATERIAL Baltic Birch (*Betula pendula*)
 FEATURES Ultra long sustain
 Authentic rain sound
 Natural birch wood construction
 COLOUR **NT:** Natural



ULTRA LONG SUSTAIN

RAINSTICKS & RAINMAKER



CHIMES

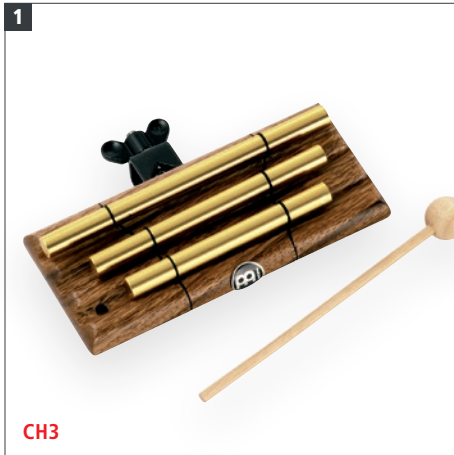

CH3



12 bars
CH-H12

18 bars
CH-H18

24 bars
CH-H24



12 pegs
CH-HPEG

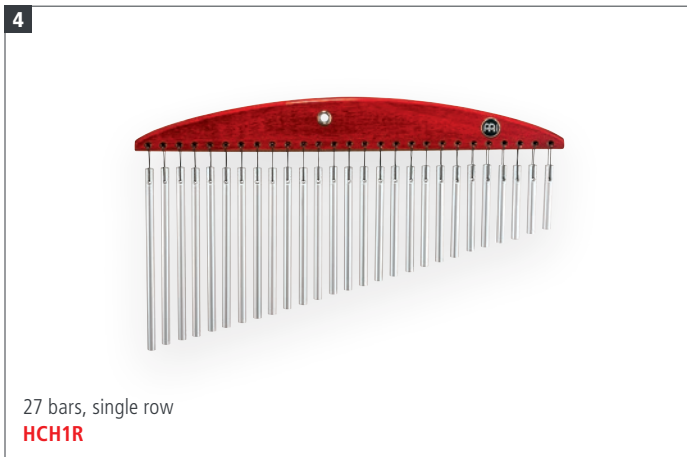

27 bars, single row
HCH1R



33 bars, single row
HCH2BK



27 bars, single row
CH27VWB

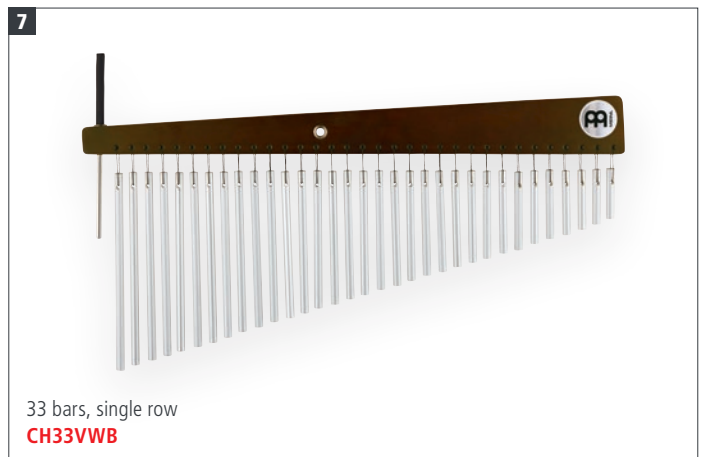

33 bars, single row
CH33VWB

1 TRI TONE CHIMES

- MATERIAL** Gold anodized aluminum alloy
- FEATURES** Three free-floating bars create a very long sustain
Tonally matched bars
Mountable on all common L-rods
- INCLUDES** Wooden beater and holder

2 HAND CHIMES

- SIZES** **CH-H12:** 12 bars
CH-H18: 18 bars
CH-H24: 24 bars
- MATERIAL** Gold anodized aluminum alloy
- FEATURES** Can easily be played by hand
Produce a full and rich sound

3 PEG CHIMES

- SIZE** 12 pegs
- MATERIAL** Gold plated steel
- FEATURE** Perfect for special accents

4 HEADLINER® SERIES CHIMES, 27 BARS

- SIZE** 27 bars, single row
- MATERIAL** Silver anodized aluminum alloy
- FEATURES** Great and affordable addition to any percussion set-up
Produce a full and warm chime sound
- COLOUR** **R:** Red

5 HEADLINER® SERIES CHIMES, 33 BARS

- SIZE** 33 bars, single row
- MATERIAL** Silver anodized aluminum alloy
- FEATURE** Generate a full sound spectrum
- COLOUR** **BK:** Black

6 VINTAGE CHIMES, 27 BARS

- SIZE** 27 bars, single row
- MATERIAL** Silver anodized aluminum alloy
- FEATURE** Excellent addition to any drum or percussion arrangement
- COLOUR** **VWB:** Vintage Wine Barrel

7 VINTAGE CHIMES, 33 BARS

- SIZE** 33 bars, single row
- MATERIAL** Silver anodized aluminum alloy
- FEATURES** Can be used in a wide range of musical styles
Producing a sweet sparkling sound
- INCLUDES** Holder; Striker
- COLOUR** **VWB:** Vintage Wine Barrel



12 bars, single row
CH12

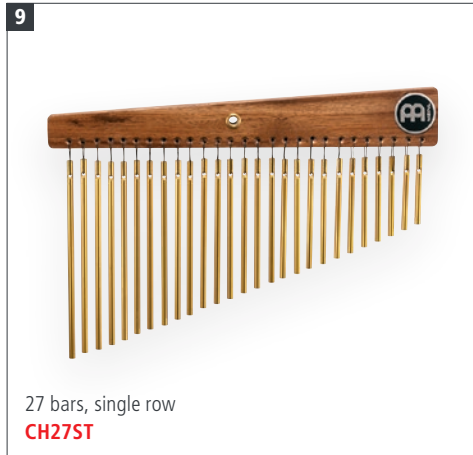

27 bars, single row
CH27ST



27 bars, single row
CH27

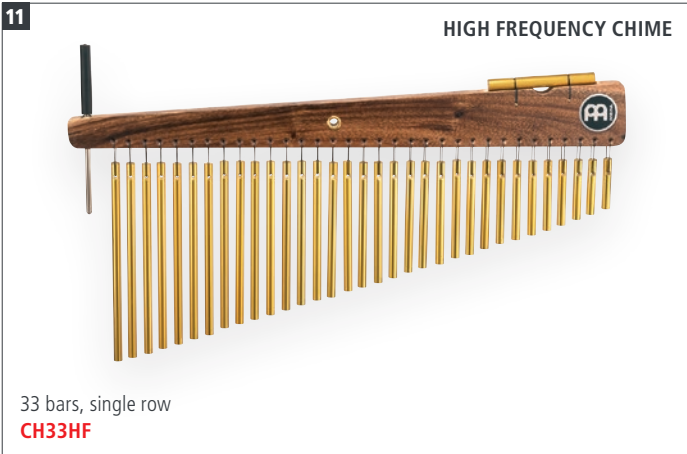

33 bars, single row
CH33HF



66 bars, double row
CH66HF

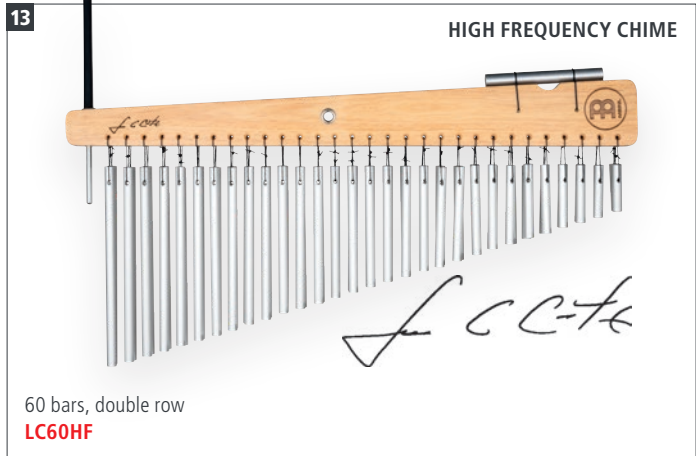

60 bars, double row
LC60HF



LUIS CONTE

8 CHIMES, 12 BARS
SIZE 12 bars, single row
MATERIAL Gold anodized aluminum alloy
FEATURES Produce a beautiful, high pitched sound
 Ideal for tasteful chime accents

9 STUDIO CHIMES, 27 BARS
SIZE 27 bars, single row
MATERIAL Gold anodized aluminum alloy
FEATURE Slightly thinner bars for a full, rich and delicate sound

10 CHIMES, 27 BARS
SIZE 27 bars, single row
MATERIAL Gold anodized aluminum alloy
FEATURES Produce a full sound with a wide tonal spectrum
 Ideal for smaller stages and club scenes

11 CHIMES, 33 BARS
SIZE 33 bars, single row
MATERIAL Gold anodized aluminum alloy
FEATURES Produce a very bright sound with a pronounced upper overtone spectrum
 Perfect for all live situations
INCLUDES Holder; Striker

12 CHIMES, 66 BARS
SIZE 66 bars, double row
MATERIAL Gold anodized aluminum alloy
FEATURES Produces a rich and full sound
 Cut through any band setting
INCLUDES Holder; Striker

13 ARTIST SERIES CHIMES LUIS CONTE
SIZE 60 bars, double row
MATERIAL Silver anodized aluminum alloy
FEATURES Produces a bright sound from the medium and low pitched bars
 Perfect for all studio situations
INCLUDES Holder; Striker

PERCUSSION STOMP BOXES & EFFECTS PEDALS

1

Kick
STB1

Cowbell
STB2

Clap
STB3

Tambourine
STB4

HiHat
STB5

2 CREATES A FOOT STOMPING ANALOG SIGNAL

Analog
MPS1

3 A WHOLE PERCUSSION KIT IN A BOX

NEW

FX5

FX20

4 NEW

MPTP

1 PERCUSSION STOMP BOXES

MATERIAL Aluminum

FEATURES Create hands-free beats by tapping your foot; Pre-programmed percussion sound effect; Perfect for cajon players, guitarists and multi-instrumentalists; High-quality 1/4" output jack

SOUNDS **STB1:** Kick
STB2: Cowbell
STB3: Clap
STB4: Tambourine
STB5: HiHat

2 PERCUSSION STOMP BOX, ANALOG

MATERIAL Solid Mahogany body

FEATURES Perfect for percussionists and multi-instrumentalists; 1/4" input and output jacks; Creates a foot stomping analog signal; Built-in Piezo pickups with volume control

INCLUDES L-shaped soft foam beater

3 EFFECTS PEDALS

MATERIALS ABS; Steel

FEATURES Ideal for multi-instrumentalists and percussionists
FX5: 5 pre-programmed sounds; Hands-free beats
FX20: Ten pre-programmed percussion samples and ten custom samples; Weighted body for a sturdy feel; Highly dynamic pedal with smooth spring back and no sound interference

INCLUDES **FX5:** Rechargeable battery, USB-C cable
FX20: Micro SD card and power supply with international adapters

SOUNDS **FX5:** 0 - Pop; 1 - Doom; 2 - SDS; 3 - 808 Sub; 4 - Soft Kick
FX20: 0 - Kick Bass; 1 - Soft Kick; 2 - 808 Bass; 3 - 808 Snare; 4 - HiHat; 5 - Clave; 6 - Hand Clap; 7 - Cowbell; 8 - Straight Tambourine; 9 - Shaker

4 TRIGGER PEDAL

MATERIAL ABS; Steel

FEATURES Pedal activated trigger; Transmits sounds from your sound module; Hands-free use

5 BASSBOX & PICKUP BASSBOX

SIZE 17 1/2" W x 6 3/4" H x 11 3/4" D

MATERIAL Resonating body: Baltic Birch (*Betula pendula*)

FEATURES Perfect for guitarists and singers; Immense bass sound
PBASSBOX: Piezo pickup with high quality output jack

INCLUDES L-shaped soft foam beater

COLOUR Black

FINISH Matte

BASSBOXES & SNAREBOXES



FOOT PERCUSSION

5 ALUMINUM RAIL TO MOUNT ANY COMMON FOOT PEDAL

Bassbox
BASSBOX

IMMENSE BASS SOUND

Pickup Bassbox
PBASSBOX

L-SHAPED SOFT FOAM BEATER INCLUDED

6 TWO INTERNAL SNARE WIRES

Snarebox
SNAREBOX

CRISP SNARE SOUND

Pickup Snarebox
PSNAREBOX

L-SHAPED FELT BEATER INCLUDED

7

Soft foam
BBB2

8

Felt
SBB1

9

Brass jingles
BBB1

10

Foam rubber
BBB3

11

Artificial fur
BBB4



12

PERFECT FOR THE MEINL BASSBOX AND SNAREBOX

TMBP



6 SNAREBOX & PICKUP SNAREBOX
 SIZE 7 1/2" W x 7 1/2" H x 13" D
 MATERIAL Baltic Birch (*Betula pendula*)
 FEATURES Perfect for guitarists and singers; Crisp snare sound
PSNAREBOX: Piezo pickup with high quality output jack
 INCLUDES L-shaped felt beater
 COLOUR Black
 FINISH Matte

7 BASSBOX BEATER
 MATERIAL Soft foam rubber
 FEATURE Punchy response

8 SNAREBOX BEATER
 MATERIAL Felt
 FEATURE Crisp snare response

9 JINGLE CONTACT BASSBOX/ SNAREBOX BEATER
 MATERIALS Soft foam rubber
 Brass jingles
 FEATURE Soft L-shaped foam rubber beater with adjustable brass jingles

10 HAMMER HEAD BASSBOX/ SNAREBOX BEATER
 MATERIAL Foam rubber
 FEATURES Hammer Head shape for a pronounced kick sound; Dual playing surfaces for boom or punch; Draws out a naturally deep tone

11 WOOLLY MAMMOTH BASSBOX/ SNAREBOX BEATER
 MATERIAL Artificial fur
 Soft foam
 FEATURES Woolly Mammoth beater produces a soft kick sound; Delivers a mellow attack for low volume and texture

12 BASSBOX/ SNAREBOX PEDAL
 MATERIAL Steel
 FEATURE Adjustable spring tension to dial in your comfort zone

FOOT PERCUSSION



Stainless steel jingles
FJS2S-BK



Stainless steel jingles
CFJS2S-BK



Stainless steel jingles
CFT5-BK



Synthetic
FS-BK



Siam Oak, Synthetic
CFC-BK



Stainless steel jingles
HTA



Stainless steel jingles
PHTA



Synthetic
HSH

1 FOOT TAMBOURINE

MATERIALS Siam Oak (*Hevea brasiliensis* Muell.-Arg.)
Stainless steel jingles
FEATURE Hassle-free mounting

2 COMPACT FOOT TAMBOURINE

MATERIALS Synthetic
Stainless steel jingles
FEATURE Attaches quickly and easily to foot via elastic strap

3 CAJON FOOT TAMBOURINE

MATERIALS Siam Oak (*Hevea brasiliensis* Muell.-Arg.)
Stainless steel jingles
FEATURES 5 pairs of stainless steel jingles
Easily mountable

4 FOOT SHAKER

MATERIAL Synthetic
FEATURES Easy mountable
Shaker mounted at a special angle for precise control

5 CAJON FOOT CASTANET

MATERIALS Siam Oak (*Hevea brasiliensis* Muell.-Arg.)
Synthetic
FEATURES Traditional castanet sound
Easily mountable
Pair of synthetic castanets

6 HEEL TAMBOURINE

MATERIALS Siam Oak (*Hevea brasiliensis* Muell.-Arg.)
Synthetic
Stainless steel jingles
FEATURES Stainless steel jingles for a bright full sound
Shoehorn design fits comfortably against your heel
Great accessory for hands free playing

7 PROFESSIONAL HEEL TAMBOURINE

MATERIALS Siam Oak (*Hevea brasiliensis* Muell.-Arg.)
Synthetic
Stainless steel jingles
FEATURES Stainless steel jingles for a bright, full sound
Adjustable mounting system fits perfectly against your heel
Great accessory for hands-free playing



Siam Oak
FR1NT

Bendo seeds
FR1B

Kenen seeds
FR1K

Pangi seeds
FR1P

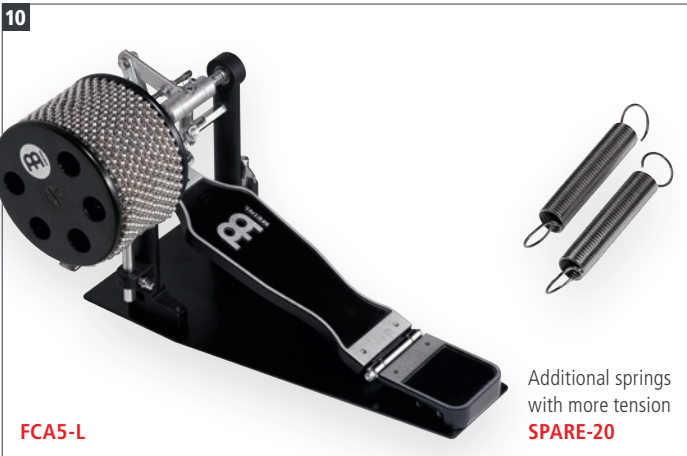

8 HEEL SHAKER

MATERIAL Synthetic
FEATURES Great accessory for hands-free playing
Shoehorn design fits comfortably against your heel

9 FOOT RATTLES

MATERIALS **FR1NT:** Siam Oak (Hevea brasiliensis Muell.-Arg.)
FR1B: Bendo seed nutshells
FR1K: Kenen seed nutshells
FR1P: Pangi seed nutshells
FEATURES Hands-free – straps securely and comfortably around your ankle
Creates a hollow wooden shaker effect with warmth and depth
Equipped with hook-and-loop strap for a universally adjustable fit

10 FOOT CABASA (PATENTED)

SIZE Large
MATERIALS Steel chain and stainless steel cylinder
Wooden body
Black powder coated pedal
FEATURES Optional single or double-stroke setting
5 sound ports on each side for more volume
INCLUDES Drum key
Foot pedal

11 TAMBOURINE HOLDER SET

MATERIAL Baltic Birch (*Betula pendula*)
CONTAINS Tambourine Holder
Headliner® Series Hand Held ABS
Tambourine (HTBK)
FEATURE Perfect for cajon players, guitarists and singers

ARTISAN EDITION CAJONS

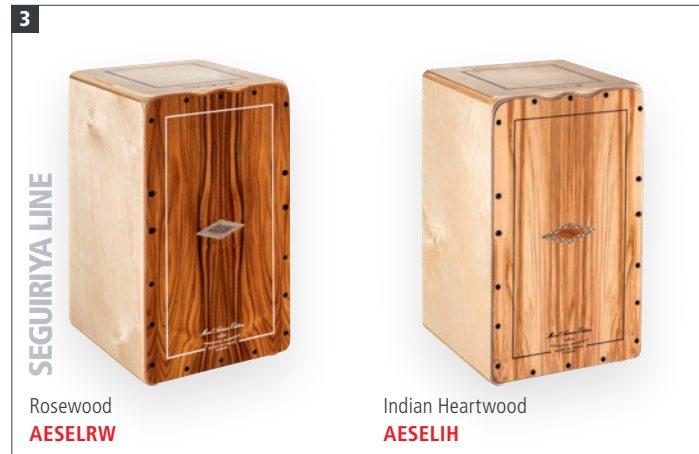

José Hernández Díaz also known as 'Pepote' – was born in Huelva (Spain) in November 1976. He inherited his passion for wood from his father and grandfather, both of whom were aficionados of woodworking and model aeroplanes.

He first came across the Cajon at the age of 13 while watching a Paco de Lucia concert on television. Inspired to make his own, he soon started receiving commissions from friends and acquaintances when they realised that the Cajon was virtually impossible to get hold of in Spain. Pepote began taking these instruments to local shops in his city when he was just 15 years old. This marked the start of his woodworking training, where he focused on the production of musical instruments by studying techniques for making ancient musical instruments and guitars while also completing his studies in industrial furniture design.

Since then, he has been continually developing the instrument and relentlessly perfecting his craft. He came up with an aesthetic based on comfort, tried and tested more than 30 different kinds of wood for construction, created a special unbreakable string for the Cajon and tried 20 different kinds of varnish for the finish. The list goes on. Everything he does revolves around getting the best possible sound out of the instrument and providing the ultimate peace of mind for the percussionist.



ARTISAN EDITION CAJONS

FEATURES Rounded corners and thumb notches for optimal playing comfort and sound
Ergonomically rounded frontplate with convex contact
Specially formulated soft rubber feet
Martinete, Fandango, Seguriya, Cantina Line:
Extra thick wooden sound port ring for compression
Two tuning screws to adjust the tension for each set of strings
Pop filter on soundhole
Seguriya, Cantina, Minera, Bulería, Soleá, Tango Line:
Elegant heat-branding on resonating body

1 MARTINETE LINE

SIZE 11 1/2" W x 19" H x 12 3/4" D
MATERIALS Resonating body: Solid Wood (15 mm)
Tulip Poplar (*Liriodendron tulipifera*)
Frontplate: Brazilian Ironwood (*Phoebe porosa*) with Ukola Woodframe
FEATURES Two sets of 10 adjustable strings (Separately per side)
6 specially formulated soft rubber feet
INCLUDES Tuning key

2 FANDANGO LINE

SIZE 11 1/2" W x 19" H x 12" D
MATERIALS Resonating body: Solid Wood (15 mm)
Tulip Poplar (*Liriodendron tulipifera*)
Frontplate: Indian Heartwood
FEATURES Two sets of 8 adjustable strings (Separately per side)
6 specially formulated soft rubber feet
INCLUDES Tuning key

3 SEGURIYA LINE

SIZE 11 1/4" W x 19" H x 11 3/4" D
MATERIALS Resonating body: 9-Ply (12 mm)
Baltic Birch (*Betula Pendula*)
AESELIH Frontplate: Indian Heartwood
AESELRW Frontplate: Rosewood
FEATURE Two sets of 8 adjustable strings (Separately per side)
INCLUDES Tuning key

4 CANTINA LINE

SIZE **AECLBE, AECLLI** 11 1/4" W x 19" H x 11 3/4" D
AECLWN 12 1/2" W x 18 1/2" H x 12 1/2" D
MATERIALS Resonating body: 9-Ply (12 mm)
Baltic Birch (*Betula Pendula*)
AECLBE Frontplate: Brown Eucalyptus
AECLLI Frontplate: Limba
AECLWN Frontplate: Walnut

6 **BULERÍA LINE** **BASS REFLEX SYSTEM**

Tulip
AEBLTL

Mongoy
AEBLMY

7 **SOLEÁ LINE** **BASS REFLEX SYSTEM**

Ebony Burst
AESLEYB

Dark Red Burst
AESLRB

8 **TANGO LINE**

Blue Fade
AETLBF

Red Fade
AETLRF

Satin Black
AETLSBK

Espresso Burst
AESLEB

Brown Eucalyptus
AETLBE

Grey Eucalyptus
AETLGE

Light Eucalyptus
AETLLE

Limba
AETLLI

FEATURES **AECLBE, AECLLI**
Forward projecting sound port;
Two sets of 6 pre-tuned strings
AECLWN
Two sets of 8 adjustable strings from the top (Separately per side);
Decorative wood inlay

INCLUDES Tuning key

5 MINERA LINE

SIZE 11 1/4" W x 19" H x 11 3/4" D

MATERIALS Resonating body: 9-Ply (12 mm)
Baltic Birch (*Betula Pendula*)
AEMILLI Frontplate: Limba
AEMILBE Frontplate: Brown Eucalyptus

FEATURE Two sets of 4 pre-tuned strings

INCLUDES Tuning key

6 BULERÍA LINE

SIZE 11 1/4" W x 19" H x 11 3/4" D

MATERIALS Resonating body: 9-Ply (12 mm)
Baltic Birch (*Betula Pendula*)
AEBLMY Frontplate: Mongoy
AEBLTL Frontplate: Tulip

FEATURES Two sets of 5 adjustable strings (Separately per side)
Tuning screw to adjust string tension
Pop filter on soundhole
Bass reflex system

INCLUDES Tuning key

7 SOLEÁ LINE

SIZE 11 1/4" W x 19" H x 11 3/4" D

MATERIALS Resonating body: 9-Ply (12 mm)
Baltic Birch (*Betula Pendula*)
Frontplate: Selected wood

FEATURES Two sets of 4 pre-tuned strings
Bass reflex system

FINISHES **AESLEB** Frontplate: Espresso Burst
AESLEYB Frontplate: Ebony Burst
AESLRB Frontplate: Dark Red Burst

8 TANGO LINE

SIZE 11 1/4" W x 19" H x 11 3/4" D

MATERIALS Resonating body: 7-Ply (9 mm)
Baltic Birch (*Betula Pendula*)
AETLBE Frontplate: Brown Eucalyptus
AETLBF Frontplate: Selected wood
AETLGE Frontplate: Grey Eucalyptus
AETLLE Frontplate: Light Eucalyptus
AETLLI Frontplate: Limba
AETLRF Frontplate: Selected wood
AETLSBK Frontplate: Selected wood

FEATURE Two sets of 3 pre-tuned strings

FINISHES **AETLBF** Frontplate: Blue Fade
AETLRF Frontplate: Red Fade
AETLSBK Frontplate: Satin Black

WOODCRAFT & HEADLINER® SERIES CAJONS



WOODCRAFT CAJONS **1** **2**

SIZE 11 3/4" W x 19 3/4" H x 12" D
FEATURES Custom micro-coiled steel cajon strings
 Baltic birch construction
 Rounded corners for added comfort
 Rubber feet and rear sound port

1 WOODCRAFT PROFESSIONAL CAJONS

MATERIALS Resonating body: 9-Ply (12 mm)
 Baltic Birch (*Betula pendula*)
WCP100MB Frontplate: Makah-Burl
WCP100MH Frontplate: Mahogany

2 WOODCRAFT CAJONS

MATERIALS Resonating body: 7-Ply (9 mm)
 Baltic Birch (*Betula pendula*)
WC100B Frontplate: Baltic Birch (*Betula pendula*)
WC100EB Frontplate: Espresso Burst

3 HEADLINER® SERIES STRING CAJONS

SIZES **HCAJ1:** 11 3/4" W x 18" H x 12 1/4" D
HCAJ3: 11 3/4" W x 19 3/4" H x 12" D
MATERIALS **HCAJ1AWA, HCAJ3AWA**

Resonating body: Eco-friendly medium density fiberboard
 Frontplate: Stained American White Ash (*Fraxinus Americana* L.)

HCAJ1NT
 Resonating body: Baltic Birch (*Betula pendula*)
 Frontplate: Baltic Birch (*Betula pendula*)
HCAJ3LJ

Resonating body: Eco-friendly medium density fiberboard
 Frontplate: Baltic Birch (*Betula pendula*)
FEATURES Adjustable top corners
 Adjustable sizzle effect
 Internal fixed cajon strings
 Wide sound options

INCLUDES **HCAJ1:** Anti-slip sitting surface
 Hex key
FINISH **AWA, NT:** Matte
LJ: Lumberjack

4 HEADLINER® SERIES SNARE CAJON

SIZE 11 3/4" W x 18" H x 11 3/4" D
MATERIALS Resonating body: Eco-friendly medium density fiberboard
MA Frontplate: Maple
CBF, LPF, PBF, SAF, TRF Frontplate: American White Ash (*Fraxinus Americana* L.)
FEATURES Dual internal fixed snare wires
 Adjustable top corner
 Wide sound options
FINISHES Matte
CBF Frontplate: Charcoal Black Fade
LPF Frontplate: Lilac Purple Fade
MA Frontplate: Natural

SNARECRAFT & JAM CAJONS



CAJONS

5 FOOT ACTIVATED SNARE SWITCH SNARE SWITCH KNOB

American White Ash Walnut
SCP100AWA **SCP100WN**

6

Almond Birch Almond Birch Baltic Birch Baltic Birch
SC80AB **SC100AB** **SC80AB-B** **SC100AB-B**

Baltic Birch Baltic Birch Burl Wood Burl Wood Heart Ash Heart Ash
SC80B **SC100B** **SC80BW** **SC100BW** **SC80HA** **SC100HA**

7

Almond Birch Baltic Birch Baltic Birch Burl Wood Heart Ash
JC50AB **JC50AB-B** **JC50B** **JC50BW** **JC50HA**

PBF Frontplate: Pacific Blue Fade
SAF Frontplate: Sonoran Amber Fade
TRF Frontplate: Tango Red Fade

SCP100WN
Equipped with a snare switch knob on the side of the cajon

Frontplate: Burl Wood
SC80HA, SC100HA, JC50HA
Resonating body: 7-Ply (9 mm)
Baltic Birch (*Betula pendula*)
Frontplate: Heart Ash

5 SNARECRAFT PROFESSIONAL CAJONS
SIZE 11 3/4" W x 19 3/4" H x 12" D
MATERIALS Resonating body: 9-Ply (12 mm)
Baltic Birch (*Betula pendula*)
SCP100AWA
Frontplate: American White Ash (*Fraxinus Americana* L.)
SCP100WN
Frontplate: Walnut
FEATURES Adjustable snare for both Flamenco and Peruvian styles
Baltic birch construction
Rounded corners for added comfort
Rubber feet and rear sound port
SCP100AWA
Equipped with a foot activated snare switch

SNARECRAFT & JAM CAJONS 6 7
MATERIALS **SC80AB, SC100AB, JC50AB**
Resonating body: 7-Ply (9 mm)
Baltic Birch (*Betula pendula*)
Frontplate: Almond Birch (*Betula pendula*)
SC80AB-B, SC100AB-B, JC50AB-B
Resonating body: 7-Ply (9 mm)
Almond Birch (*Betula pendula*)
Frontplate: Baltic Birch (*Betula pendula*)
SC80B, SC100B, JC50B
Resonating body: 7-Ply (9 mm)
Baltic Birch (*Betula pendula*)
Frontplate: Baltic Birch (*Betula pendula*)
SC80BW, SC100BW, JC50BW
Resonating body: 7-Ply (9 mm)
Baltic Birch (*Betula pendula*)

6 SNARECRAFT CAJONS
SIZES **SC80:** 11 3/4" W x 18" H x 11 3/4" D
SC100: 11 3/4" W x 19 3/4" H x 11 3/4" D
FEATURES Dual internal fixed snare wires
Baltic birch construction
Rounded corners for added comfort
Rubber feet and rear sound port

7 JAM CAJONS
SIZE 10 1/2" W x 15" H x 10 1/4" D
FEATURES Compact size
Baltic birch construction
Dual internal fixed snare wires
Rubber feet and rear sound port

CAJONS

1

VIDALITA LINE



Palo Santo, satin
AEVLPS

2



Makah-Burl, matte
TOPCAJ1MB

Walnut, matte
TOPCAJ2WN

3

CONTRASTING PLAYING SURFACES ON OPPOSITE SIDES





Baltic Birch, matte
HTOPCAJ3NT

4



caiXoN
VR-CAIX

caiXoNet
VR-CAIXN

Set, 2 pcs.
VR-CAIX/CAIXN

STACKABLE FOR EASY STORAGE AND TRANSPORTATION



5

BACK

SOUND PORT FOR CLEAR PROJECTION



Black, matte
TCAJ1BK

6

NEW

FORWARD FACING SOUND PORTS



TTOPCAJ1

7

INTERNAL SNARE WIRES



Natural/Ebony Black, matte
BCA2NT/EBK-M

DIFFERENT SIZED CHAMBERS ENABLE AN AUTHENTIC BONGO EFFECT



Super Natural, matte
BCA1SNT-M

8

NEW

TWO SOUND OPTIONS



TMBX

1 ARTISAN EDITION SLAPTOP CAJON, VIDALITA LINE

SIZE 17 3/4" W x 10" H x 12 1/2" D
MATERIALS Resonating body: 6 mm birch plywood; Playing surface: Palo Santo (*Bursera graveolens*)
FEATURE Enlarged Baltic Birch body with upward facing front port for deep bass

2 SLAPTOP CAJONS (PATENTED)

SIZES **TOPCAJ1MB**
14 1/2" W x 8 3/4" H x 5 3/4" D
TOPCAJ2WN (Turbo Slaptop)
14 1/2" W x 10" H x 5 3/4" D
MATERIALS **TOPCAJ1MB** Resonating body: Eco-friendly medium density fiberboard; Playing surface: Makah-Burl
TOPCAJ2WN (Turbo Slaptop)
Resonating body: Eco-friendly medium density fiberboard; Playing surface:

Walnut (*Juglans regia* L.)

FEATURES Comfortable upright playing style; Forward facing sound ports; Dual internal fixed snare wires; Deep bass and cutting slap tones
TOPCAJ2WN (Turbo Slaptop)
Snare on both sides

3 HYBRID SLAPTOP CAJON

SIZE 14 1/2" W x 10" H x 5 3/4" D
MATERIAL Baltic Birch (*Betula pendula*)
FEATURES Comfortable and unique X-design; Forward sound projection; Dual internal fixed snare wires for a snare cajon sound on one side; Bongo cajon sound on the opposite side

4 CAIXON & CAIXONET

SIZES **VR-CAIX** (caiXoN)
11 1/2" W x 26 1/4" H x 12" D
VR-CAIXN (caiXoNet)
10 1/2" W x 26 1/4" H x 9 1/2" D

MATERIALS Resonating body: Baltic Birch (*Betula pendula*); Playing surface: Striped Onyx
FEATURES Internal snare wires for cutting snare slaps; Perfect for seated players; Forward facing sound port
VR-CAIX: Deep bass tones
VR-CAIXN: Higher tones
VR-CAIX/CAIXN: Includes large caiXoN and smaller caiXoNet; Stackable for easy storage and transportation

5 TRAVEL CAJON

SIZE 11 3/4"
MATERIAL Siam Oak (*Hevea brasiliensis* Muell.-Arg.)
FEATURES Internal snare wires; Compact design

6 TRAVEL SLAPTOP CAJON

SIZE 18 3/4" W x 2 3/4" H x 9 1/2" D
MATERIALS Resonating body: Eco-friendly medium density fiberboard; Playing surface: Maple

BASS CAJONS



CAJONS

FEATURES Comfortable upright playing style; Forward facing sound ports; Dual internal fixed snare wires; Crisp snare cajon sound

7 BONGO CAJONS

SIZE 15 3/4" W x 6 3/4" H x 7 1/4" D
MATERIAL Siam Oak (*Hevea brasiliensis* Muell.-Arg.)
FEATURES High and low pitch playing surface; Compact size and light weight
BCA2: Dual internal fixed snare wires

8 BOXITO

SIZE 11" W x 8 1/2" H x 5 3/4" D
MATERIALS Resonating body: Baltic Birch (*Betula pendula*); Playing surface: Baltic Birch (*Betula pendula*), Exotic Zebrano
FEATURES Dual playing surfaces bongo/snare; Internal fixed snare wires; Natural wood tone

9 JUMBO ARCH BASS CAJON

SIZE 16" W x 19 3/4" H x 13 1/2" D
MATERIALS Resonating body: Siam Oak (*Hevea brasiliensis* Muell.-Arg.); Frontplate: Maple
FEATURES Arched sides and back for low note development; Extra wide dimensions; Dual internal fixed snare wires; Enhanced boomy and punchy bass sounds

10 ARCH BASS CAJON

SIZE 15 1/4" W x 18" H x 12" D
MATERIALS Resonating body: Siam Oak (*Hevea brasiliensis* Muell.-Arg.); Frontplate: Maple

11 EBONY BASS FOOT SWITCH CAJON

SIZE 13 1/4" W x 19 3/4" H x 13 1/2" D
MATERIALS Resonating body: Baltic Birch (*Betula pendula*); Frontplate: Ebony
FEATURES Foot activated snare switch; Extra wide body for deep bass

12 VERTICAL SUBWOOFER CAJON

SIZE 15 1/2" W x 19 1/4" H x 11 3/4" D
MATERIALS Resonating body: Eco-friendly medium density fiberboard; Frontplate: Makah-Burl
FEATURE Dual internal fixed snare wires and bass reflex channel

13 SUBWOOFER CAJONS

SIZES **SUBCAJ1AWA** 11 3/4" W x 19 3/4" H x 12 1/4" D
SUBCAJ5WN 13 1/2" W x 19 3/4" H x 13 3/4" D
MATERIALS Resonating body: Eco-friendly medium density fiberboard
SUBCAJ1AWA Frontplate: American White Ash (*Fraxinus Americana* L.)
SUBCAJ5WN Frontplate: Walnut (*Juglans regia* L.)
FEATURES Forward projecting sound port; Dual internal fixed snare wires

PICKUP CAJONS

1 **PIEZO PICKUP WITH VOLUME AND TONE CONTROL**



SOLEÁ LINE

Dark Olive Burst
PAESLDOB

2



Baltic Birch
PWC100B

Makah-Burl
PWCP100MB

3



Baltic Birch
PSC100NT

Baltic Birch
PSC100B

4



Baltic Birch
PJC50B

5



Baltic Birch
PSUBCAJ6B

6 **INDIVIDUAL SNARE AND BASS CONTROL**



Walnut
PTOPCAJ2WN

Mahogany
PTOPCAJ4MH-M

1 ARTISAN EDITION PICKUP CAJON, SOLEÁ LINE

SIZE 11 1/4" W x 19" H x 11 3/4" D
MATERIALS Resonating body: 9-Ply (12 mm) Baltic Birch (*Betula pendula*)
 Frontplate: Dark Olive Burst
FEATURES Piezo pickup with volume and tone control; Two sets of 4 pre-tuned strings; Rounded corners and thumb notches for optimal playing comfort and sound; Ergonomically rounded frontplate with convex contact; Bass reflex system

2 PICKUP WOODCRAFT SERIES CAJONS

SIZE **PWCP100MB** (Woodcraft Professional) 11 3/4" W x 19 3/4" H x 12" D
PWC100B (Woodcraft) 11 3/4" W x 19 3/4" H x 12" D
MATERIALS Resonating body: Baltic Birch (*Betula pendula*)

PWCP100MB (Woodcraft Professional)
 Frontplate: Makah-Burl
PWC100B (Woodcraft)
 Frontplate: Baltic Birch (*Betula pendula*)
FEATURES Three Piezo pickups for snare and bass sounds; Rubber feet and rear sound port
COLOURS **PWCP100MB**
 Resonating body: Black
PWC100B
 Resonating body: Natural

3 PICKUP SNARECRAFT SERIES CAJONS

SIZE 11 3/4" W x 19 3/4" H x 11 3/4" D
MATERIALS Resonating body: Baltic Birch (*Betula pendula*)
 Frontplate: Baltic Birch (*Betula pendula*)
FEATURES Three Piezo pickups for snare and bass sounds; Baltic birch construction
COLOURS **PSC100B**
 Resonating body: Black

PSC100NT
 Resonating body: Natural

4 PICKUP JAM CAJON

SIZE 10 1/2" W x 15" H x 10" D
MATERIALS Resonating body: Baltic Birch (*Betula pendula*)
 Frontplate: Baltic Birch (*Betula pendula*)
FEATURES Compact size; Dual internal fixed snare wires; Piezo pickup with volume control
COLOUR Natural

5 PICKUP VERTICAL SUBWOOFER CAJON

SIZE 15 1/2" W x 19 1/4" H x 11 3/4" D
MATERIALS Resonating body: Eco-friendly medium density fiberboard
 Frontplate: Baltic Birch (*Betula pendula*)
FEATURES Vertical forward-facing sound ports; Piezo pickup with volume and tone control; Dual internal fixed snare wires

7





Birch Wood
MPDC1

DIGITAL CAJON FOR EXPANDED SOUND OPTIONS AND SILENT PRACTICE

DIGITAL CAJON SOUNDS

- 0 - MEINL Subwoofer Cajon + MEINL Tambourine
- 1 - MEINL Snarecraft Cajon + MEINL Splash Cymbal
- 2 - MEINL Cantina Line Artisan Cajon + MEINL Closed Hihat Cymbal
- 3 - MEINL Slaptop Cajon + Hand Clap
- 4 - MEINL Woodcraft Cajon + MEINL Crash Cymbal
- 5 - Rock Drum Kit + MEINL Closed Hihat Cymbal
- 6 - Drum Machine + MEINL Ride Cymbal
- 7 - MEINL Marathon® Classic Congas
- 8 - MEINL Fibercraft Bongos + MEINL Percussion Block
- 9 - MEINL Diego Galé Signature Timbales + MEINL Steel Craft Cowbell

9



Baltic Birch
MMCS

CAJON MICROPHONE STAND (SEE PAGE 92)



CMS

8

TWO 4.5" 20-WATT SPEAKERS



Baltic Birch
MPSCAJ

PRACTICE TO MUSIC OR INCORPORATE LOOPS IN YOUR PERFORMANCES

10



MIC-PERC

11



PA-CAJ

MICROPHONE CAJON CLAMP (SEE PAGE 99)



MPMCC

6 PICKUP SLAPTOP CAJONS (PATENTED)

SIZES **PTOPCAJ2WN** (Turbo Slaptop) 14 1/2" W x 10" H x 5 3/4" D
PTOPCAJ4MH-M 15 1/2" W x 8 1/2" H x 7 1/2" D

MATERIALS **PTOPCAJ2WN** (Turbo Slaptop) Resonating body: Baltic Birch (*Betula pendula*)
Playing surface: Walnut (*Juglans regia* L.)
PTOPCAJ4MH-M Resonating body: Eco-friendly medium density fiberboard
Playing surface: Mahogany

FEATURES Passive pickup system with high quality output jack; Individual snare, bass, and tone control; Playing surface with dual internal fixed snare wires; Forward facing sound ports
PTOPCAJ2WN (Turbo Slaptop) Snares on both sides

7 DIGITAL CAJON

SIZE 12" W x 20" H x 12" D

MATERIALS Resonating body: Birch Wood
Playing surface: Open cell acoustic foam

FEATURES Four rubber trigger pads in a natural cajon playing position; Ten pre-programmed digital sounds

INCLUDES Power supply; Foot switch

COLOUR Black

8 SPEAKER CAJON

SIZE 11 3/4" W x 19 3/4" H x 11 3/4" D

MATERIALS Resonating body: Baltic Birch (*Betula pendula*)
Frontplate: Baltic Birch (*Betula pendula*)

FEATURES Practice to music or incorporate loops in your performances; Supports wireless connection with your phone

INCLUDES Micro SD card

COLOUR Resonating body: Black

9 MINI CAJON SPEAKER

SIZE 5 3/4" W x 8 3/4" H x 5 3/4" D

MATERIALS Resonating body: 5-Ply (6 mm) Baltic Birch (*Betula pendula*)
Frontplate: Baltic Birch (*Betula pendula*)

FEATURES Listen to your favorite music or podcast; Supports wireless, USB and auxiliary connection; Great gift idea for percussionists

10 PERCUSSION MICROPHONE

FEATURES Low-profile condenser microphone with adhesive backing; Great for cajons, congas, djembes or frame drums

INCLUDES Eighth-inch cable to quarter-inch adapter

11 CAJON PREAMP

FEATURES Robust Cajon Pickup/Preamp; Wide range tone control; High-quality signal output; Fits most cajons

MINI & MAKE YOUR OWN CAJONS

1

MINIATURE SIZE OF A CAJON WITH INTERNAL FIXED SNARE WIRES



Almond Birch
MC1AB

Baltic Birch
MC1AB-B

Baltic Birch
MC1B

Burl Wood
MC1BW

Heart Ash
MC1HA



2

ALL NEEDED TOOLS INCLUDED



Burl Wood
DMYO-CAJ-BU

DELUXE MODEL
FEATURES LARGER SIZE

3



Baltic Birch
MYO-CAJ

4

POPS UP FROM A FLAT PIECE INTO A FULL SIZE CAJON



Cajon2Go
VR-CAJ2GO

5



Baltic Birch
MYO-BCAJ

3



Ovangkol
MYO-CAJ-OV

ASSEMBLY INSTRUCTION COMES
IN DIFFERENT LANGUAGES

6



MYO-TOOLS

<p>1 MINI CAJONS</p> <p>SIZE 5 3/4" W x 8 3/4" H x 5 3/4" D</p> <p>MATERIALS MC1AB Resonating body: 5-Ply (6 mm) Baltic Birch (<i>Betula pendula</i>) Frontplate: Almond Birch (<i>Betula pendula</i>)</p> <p>MC1AB-B Resonating body: 5-Ply (6 mm) Almond Birch (<i>Betula pendula</i>) Frontplate: Baltic Birch (<i>Betula pendula</i>)</p> <p>MC1B Resonating body: 5-Ply (6 mm) Baltic Birch (<i>Betula pendula</i>) Frontplate: Baltic Birch (<i>Betula pendula</i>)</p> <p>MC1BW Resonating body: 5-Ply (6 mm) Baltic Birch (<i>Betula pendula</i>) Frontplate: Burl Wood</p>	<p>MC1HA Resonating body: 5-Ply (6 mm) Baltic Birch (<i>Betula pendula</i>) Frontplate: Heart Ash</p> <p>FEATURES Internal fixed snare wires; Miniature size; Birch construction; Great gift idea</p> <p>MAKE YOUR OWN 2 3 4</p> <p>CONTAINS All of the materials and assembly instructions for completing the cajon</p> <p>2 DELUXE MAKE YOUR OWN CAJON</p> <p>SIZE 12" W x 19 1/4" H x 12" D</p> <p>MATERIALS Resonating body: Baltic Birch (<i>Betula pendula</i>) Frontplate: Burl Wood</p> <p>INCLUDES All of the tools for completing the cajon</p>	<p>3 MAKE YOUR OWN CAJONS</p> <p>SIZE 11 3/4" W x 18" H x 11 3/4" D</p> <p>MATERIALS Resonating body: Baltic Birch (<i>Betula pendula</i>) MYO-CAJ Frontplate: Baltic Birch (<i>Betula pendula</i>) MYO-CAJ-OV Frontplate: Ovangkol (<i>Guibourtia ehie</i>) Steel snare wires</p> <p>COLOUR Natural</p> <p>4 CAJON2GO</p> <p>SIZE 13 1/2" W x 18" H x 12 1/2" D</p> <p>MATERIAL Cardboard</p> <p>FEATURES Folds from a single flat piece into a full size cajon Internal fixed set of snare wires Comfortably holds up to 150 kg / 330 lbs Naturally deep bass and crisp snare sounds</p>
--------------------------------------------------------------------------------------------------------------------------------------------------------------------------------------------------------------------------------------------------------------------------------------------------------------------------------------------------------------------------------------------------------------------------------------------------------------------------------------------------------------------------------------------------------------------------------------------------------------------------------------------------------------------------------------	------------------------------------------------------------------------------------------------------------------------------------------------------------------------------------------------------------------------------------------------------------------------------------------------------------------------------------------------------------------------------------------------------------------------------------------------------------------------------------------------------------------------------------------------------------------------------------------------------------------------------------------	--------------------------------------------------------------------------------------------------------------------------------------------------------------------------------------------------------------------------------------------------------------------------------------------------------------------------------------------------------------------------------------------------------------------------------------------------------------------------------------------------------------------------------------------------------------------------------------------------------------------------------------------------------------------------------------------------

CAJON PEDALS



7

SPECIALLY POSITIONED CURVED STEEL BAR WITH DIRECT DRIVE

TMSTCP



8

ADJUSTABLE SPRING TENSION ON BOTH THE PEDAL AND THE MOUNT

TMCP

BASSBOX/ SNAREBOX PEDAL (SEE PAGE 31)

TMBP

10

FOR PRONOUNCED KICK SOUND

Foam rubber

CPB1

9

CAN BE PLAYED WITH YOUR HEEL OR TOES

TMSTCP-2

11

ADJUSTABLE BRASS JINGLES

Soft foam

CPB2

12

DELIVERS HEAVY, FULL STROKES

Polymer bristles

CPB3

13

FOR DEEP AND PUNCHY NOTES

Soft foam

CPB4

14

GREAT FOR LOW VOLUME SETTINGS

Artificial fur

CPB5

5 MAKE YOUR OWN BONGO CAJON

SIZE 15 3/4" W x 6 3/4" H x 7 1/4" D
MATERIAL Baltic Birch (*Betula pendula*)
COLOUR Natural

6 MAKE YOUR OWN CAJON TOOL BOX

CONTAINS 1 x screwdriver; 1 x wood glue; 2 x tension straps; 2 x sanding pads (coarse and fine)
FEATURE One-stop shop for all necessary tools to complete the MEINL Make Your Own Cajons and Bongo Cajon

7 DIRECT DRIVE CAJON PEDAL

MATERIAL Steel
FEATURES Cradle-like mount fits all common cajons; Adjustable spring tension; Natural foot position for ease of use

8 CAJON PEDAL

MATERIALS Steel; Synthetic
FEATURES Cradle-like mount fits all common cajons; Ultra-smooth and durable cable; Position anywhere for optimal playability
INCLUDES Drum key; Soft foam beater

9 DIRECT DRIVE HEEL ACTIVATED CAJON PEDAL

MATERIAL Steel
FEATURES Simple design for steady bass drum rhythms; Cradle-like mount fits most cajons

10 HAMMER HEAD CAJON & BASS DRUM BEATER

MATERIAL Foam rubber
FEATURES Soft foam rubber draws a deep bass sound from cajons; Dual playing surfaces for a variety of boom and punch

11 JINGLE CONTACT CAJON & BASS DRUM BEATER

MATERIALS Soft foam rubber; Brass jingles
FEATURES Easily turn the jingles on or off as desired throughout your set

12 BRUSH CAJON & BASS DRUM BEATER

MATERIAL Rippled polymer bristles
FEATURES Extra thick set of wavy polymer bristles; Two adjustable control rings; Warm, slightly mellow attack

13 STANDARD CAJON & BASS DRUM BEATER

MATERIAL Soft foam rubber

14 WOOLLY MAMMOTH CAJON BEATER

MATERIALS Artificial fur; Soft foam

CAJON DRUM SETS

1



MORE INFO

MAY BE EASILY ARRANGED FOR RIGHT OR LEFT HANDED PLAYERS



Set
CAJ-DRUMSET

PORTABLE RHYTHM STATION



2



MDTK

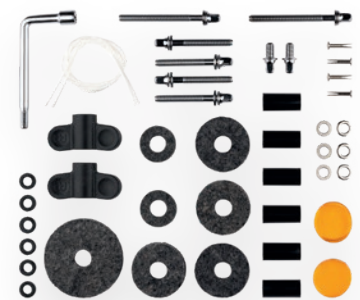

1 CAJON DRUM SET

CONTAINS Birch wood cajon without snares for enhanced bass
Cajon Pedal
Mountable Cajon Snare including silicone protection cover
Multi-Clamp
HCS 13" hihat cymbal pair with Low Hat
Bamboo Flex Multi-Rods for Cajon
Cajon Blanket with pockets for accessories
Luis Conte Live Shaker
Cajon Gig Bag

FEATURES

May be easily arranged for right or left handed players
This set includes everything needed for players looking to perform their normal drum set rhythms in smaller, intimate acoustic settings
The elements of this set give you the same feeling as sitting down at a drum kit

2 DRUM TECH KIT

CONTAINS 1 x L-Shaped Drum Key
4 x Drum Honey Gel Pads
6 x Synthetic Cymbal Sleeves
4 x Steel Cymbal Rivets
4 x Cymbal Felts
2 x Hihat Clutch Felts
1 x Hihat Base Felt
2 x 8 mm Wing Nuts
6 x Metal Washers
6 x Synthetic Washers
2 x Nylon Snare Cords
2 x Short Tension Rods
4 x Medium Tension Rods
2 x Long Tension Rods

FEATURES

Includes 14 of the most common and important tools for drummers and techs; For gig emergencies, routine maintenance, restoration or replacing lost parts

INCLUDES

Storage container for organization

CONVERTS ANY STANDARD CAJON INTO A BASS DRUM

3



MORE INFO



Set
CAJ-KIT

4

CUTTING SNARE SOUND



MCS1-BK



5

SHIELDS YOUR SNARE CAJON FROM STICK MARKS OR SCRATCHES



SCOVER



3 CAJON DRUM SET CONVERSION KIT

- CONTAINS** Direct Drive Cajon Pedal
Mountable Cajon Snare including silicone protection cover
Multi-Clamp
HCS 13" hihat cymbal pair with Low Hat
Bamboo Flex Multi-Rods for Cajon
Cajon Blanket with pockets for accessories
Luis Conte Live Shaker
Cajon Gig Bag

- FEATURES** Converts any standard cajon into a bass drum (cajon not included)
Expand your cajon into a small, reduced volume drum set
Low-key stage footprint
Perfect for acoustic shows, jam sessions, or street performances

4 MOUNTABLE CAJON SNARE

- SIZE** 7 1/2"
MATERIAL Siam Oak (*Hevea brasiliensis* Muell.-Arg.)
FEATURES Internal Snare Wires
Standard 3/8" rod mounting bracket
INCLUDES L-shaped rod with knurled surface
COLOUR **BK**: Black

5 SILICONE PROTECTION COVER

- SIZE** 7 1/2"
MATERIAL Silicone
FEATURES Shields your snare cajon from stick marks or scratches
Removable at any time

CAJON DRUM SETS



1 COCKTAIL CAJON KIT

CONTAINS Cocktail Cajon; Tom Tap; Snare Tap; Bongo Cajon Tap; Husk Brush (SB307); Foot Pedal (TMBP); Pedal Beater (CPB4); 3 x L-shaped rod (MC-R5); Splitter

2 COCKTAIL CAJON

SIZE 11 3/4" W x 19 3/4" H x 11 3/4" D
MATERIALS Resonating body: 7-Ply (9 mm) Baltic Birch (*Betula pendula*)
 Frontplate: Baltic Birch (*Betula pendula*)
FEATURES Baltic birch cajon with forward facing ports and no snares for more bass; Piezo pickups for extra amplification

3 KICK DRUM CAJON

SIZE 11 3/4" W x 19 3/4" H x 11 3/4" D
MATERIALS Resonating body: 7-Ply (9 mm) Baltic Birch (*Betula pendula*)
 Frontplate: Baltic Birch (*Betula pendula*)

FEATURES Multiple attachments to build an acoustic drum setup; Full size cajon without snares or strings for pure bass tone
INCLUDES Cymbal arm; Z-shape rod (plus mounts); pedal attachment plate; cajon beater

4 PICKUP BONGO CAJON

MATERIAL Baltic Birch (*Betula pendula*)
FEATURES High and low note playing areas; Piezo pickup and quarter-inch output jack

PICKUP CAJON TAPS 5 6

SIZE 10 3/4"
MATERIAL Baltic Birch (*Betula pendula*)
FEATURES Piezo pickup, quarter-inch output jack and volume knob; Ideal for acoustic shows

5 PICKUP CAJON SNARE TAP

FEATURE Hollow wooden body with internal snare produces a crisp snare drum sound

6 PICKUP CAJON TOM TAP

FEATURE Hollow wooden body produces a high-pitched tom sound

7 COMPACT PERCUSSION PAD

SIZE 6 1/2"
MATERIAL ABS
FEATURES 5 pre-programmed sounds; Ideal for multi-instrumentalists and percussionists; Sensitive rubber surface for responsive hand and stick notes
INCLUDES Rechargeable battery and USB-C cable
SOUNDS 9000, SDS & 808 Snare, Tambourine, Hand Clap

8 MERGER

MATERIAL Aluminum
FEATURES Combine multiple percussion audio signals into one output; Contains 6 inputs, 1 XLR output and 1 AUX input

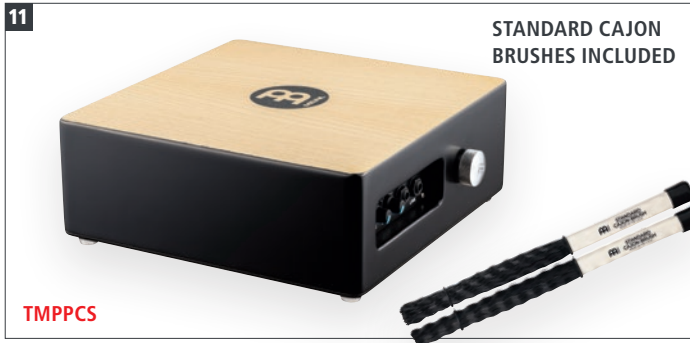

TMPPCS

STANDARD CAJON
BRUSHES INCLUDED

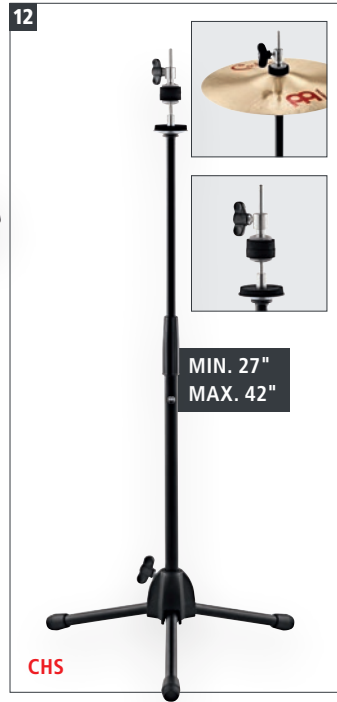

CHS

MIN. 27"
MAX. 42"

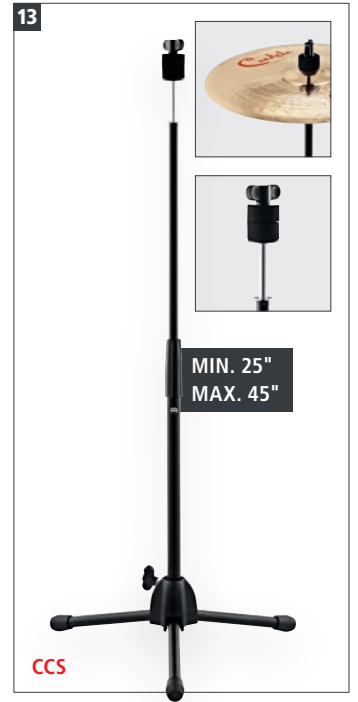

CCS

MIN. 25"
MAX. 45"



CAS

MIN. 22"
MAX. 37"



CJT



CST



CTT



MCS2-BK

INCLUDES SILICONE
PROTECTION COVER

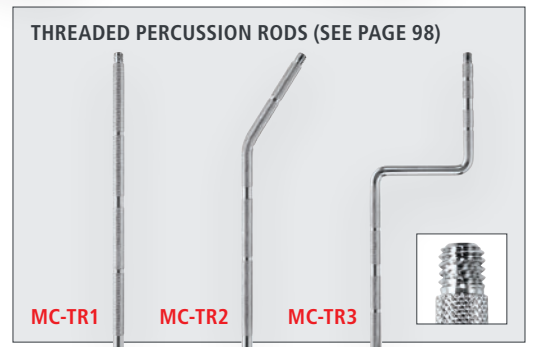

MC-TR1

MC-TR2

MC-TR3

THREADED PERCUSSION RODS (SEE PAGE 98)

9 INSTRUMENT CABLES

- SIZES
MPIC-5: 5 ft / 1.5 m
MPIC-10: 10 ft / 3 m
MPIC-15: 15 ft / 4.5 m
MPIC-20: 20 ft / 6 m
MPIC-30: 30 ft / 9 m

FEATURES 8 mm diameter with high-quality 1/4" straight connectors; Wire gauge: 24 AWG

10 COCKTAIL CAJON INSTRUMENT CABLE SET

- CONTAINS 4 x 5 ft Instrument Cable (MPIC-5)
 1 x 30 ft Instrument Cable (MPIC-30)
 FEATURE 5-piece MEINL Percussion Instrument Cable set for the MEINL Cocktail Cajon Kit

11 PROFESSIONAL PICKUP CAJON SNARE

- SIZE 13" W x 6" H x 13" D
 MATERIALS Resonating body: MDF
 Playing surface: American White Ash (*Fraxinus Americana* L.)

INCLUDES Standard Cajon Brushes (SB305)

CAJON DRUM SET STANDS 12 13 14

- MATERIAL Black powder coated steel
 FEATURE Foldable legs, height adjustable

12 CAJON HIHAT STAND

- FEATURES Standard hihat clutch and padded seat;
 Fixed internal rod for closed hihat sound

13 CAJON CYMBAL STAND

- FEATURES Standard cymbal stand top;
 Use with any cymbal type

14 CAJON ADD-ON STAND

- FEATURE 3/8" threaded connector top

CAJON TAPS 15 16 17

- SIZE 5 3/4"
 MATERIAL Siam Oak (*Hevea brasiliensis* Muell.-Arg.)

- FEATURE Threaded 3/8" connection underneath
 FINISH Black

15 CAJON JINGLE TAP

- FEATURE Stainless steel jingles for bright accents

16 CAJON SNARE TAP

- FEATURE Internal snares for high pitched snare cajon sound

17 CAJON TOM TAP

- FEATURE Hollow inside for a high pitched "tom" sound

18 MOUNTABLE CAJON SNARE WITH THREADED 3/8" CONNECTION

- SIZE 7 1/2"
 MATERIAL Siam Oak (*Hevea brasiliensis* Muell.-Arg.)
 INCLUDES Silicone Protection Cover
 COLOUR **BK:** Black

CAJON ADD-ONS

1

DESIGNED TO HOLD OUR CAJON ADD-ONS CLOSE TO THE PLAYING SURFACE

Medium **CSM-M** Large **CSM-L**

2

WC1-M

3 **STAINLESS STEEL JINGLES**

WJC1-M

ADD NEW SOUNDS TO YOUR CAJON

4 **STAINLESS STEEL JINGLES**

JT-S-BK

5 **EXTRA POCKET FOR SMALL PERCUSSION**

CAJ-BLK

6 **INTERNAL SNARE EFFECT**

WSS1BK

7

Small **CCAB-S** Medium **CCAB**

8

TMCTK

1 CAJON SIDE MOUNTS

SIZES **M:** Medium
L: Large

MATERIAL Siam Oak (*Hevea brasiliensis* Muell.-Arg.)

FEATURES Easy handling; Hook and loop fastener goes on any surface; Offers better cajon accessory placement

COLOUR Black

2 CAJON CASTANET

SIZE **M:** Medium

MATERIAL Siam Oak (*Hevea brasiliensis* Muell.-Arg.)

FEATURES Spring-opened; Hook and loop fastener goes on any surface

COLOUR Black

FINISH Matte

3 CAJON JINGLE CASTANET

SIZE **M:** Medium

MATERIAL Siam Oak (*Hevea brasiliensis* Muell.-Arg.)

FEATURES Spring-opened; Hook and loop fastener goes on any surface; Stainless steel jingles

COLOUR Black

FINISH Matte

4 JINGLE TAP

SIZE Medium

MATERIAL Siam Oak (*Hevea brasiliensis* Muell.-Arg.)

FEATURES Stainless steel jingles; Hook and loop fastener goes on any surface

COLOUR **BK:** Black

5 CAJON BLANKET

MATERIAL Heavy-duty nylon

FEATURES Fits on any cajon; Hook and loop fastener to mount additional add-ons

COLOUR Black

6 WOOD SIDE SNARE

MATERIAL Siam Oak (*Hevea brasiliensis* Muell.-Arg.)

FEATURES Internal snare effect; Hook and loop fastener attaches to Cajon body; Ergonomic shape; Unobtrusive low profile

COLOUR **BK:** Black

FINISH Matte

7 CAJON TURBO CABASAS

SIZES **CCAB-S:** Small
CCAB: Medium (traditional size)

MATERIALS Steel chain and stainless steel cylinder

FEATURES Add cabasa or loose hihat effects to cajon grooves; Five sound ports for extra projection

8 CAJON KINETIC TUNING KEY

MATERIAL Molded ABS

FEATURES Adjust cajon string tension and cajon frontplate screws; Dual crosshead screw-driver and hex key; Wide wing MEINL logo designed for a firm grip



9 KNEE PAD JINGLE TAP & KNEE PAD SNARE TAP

MATERIAL Siam Oak (*Hevea brasiliensis* Muell.-Arg.)
FEATURES Strap with hook and loop fastener to mount on your leg
KP-JT-BK: Stainless steel jingles
KP-ST-BK: Snare effect
COLOUR **BK:** Black

10 MOTION SHAKER

MATERIAL Synthetic
FEATURES Comfortable to wear on your fingers; Cutting shaker sound
COLOUR **BK:** Black

11 CAJON RING CASTANETS

SIZE Large
MATERIALS **CRC1BK:** Siam Oak (*Hevea brasiliensis* Muell.-Arg.)
PCRC1BK: Synthetic

COLOUR **BK:** Black

12 FINGER JINGLES

MATERIALS Siam Oak (*Hevea brasiliensis* Muell.-Arg.)
FJS1A: Aluminum jingles
FJS1S: Stainless steel jingles

13 CAJON PEDAL MOUNT

MATERIAL Baltic Birch (*Betula pendula*)
FEATURES Play your cajon just like a kick drum; Accommodates any size cajon; Fits all bass drum pedals; Adjustable wooden plate secures your cajon

14 SYNTHETIC LEATHER CAJON SEATS

MATERIAL Sleek faux leather
FINISHES **GR:** Grey
VBR: Vintage Brown

15 DELUXE CAJON SEATS

SIZE 9 3/4" x 9 1/2"
MATERIALS Inner material foam
 Outer material leatherette
FEATURES Provides comfort while sitting on your cajon; Filled with extra-thick padding; Elegant cross-stitching for high-end look and durability; Special underside surface grips any cajon (no adhesives necessary)
COLOURS **DCS:** Black
DCS-R: Bordeaux

16 CAJON PAD

SIZE 10" x 10"
MATERIAL Soft foam

17 CAJON PERC PACK

CONTAINS Cajon Pad; Compact Foot Tambourine; Motion Shaker; Cajon Castanet, large; Luis Conte Live Shaker

ROPE TUNED TRAVEL SERIES & JR. DJEMBES

1

GALACTIC BLUE TIE DYE



12" **PADJ8-L-F**
10" **PADJ8-M-F**

DAY OF THE DEAD



12" **PADJ7-L-F**
10" **PADJ7-M-F**

KANGA SARONG



12" **PADJ6-L-F**
10" **PADJ6-M-F**

SIMBRA



12" **PADJ5-L-F**
10" **PADJ5-M-F**



SYNTHETIC HEAD

PHARAOH'S SCRIPT



14" **PADJ1-XL-F**
12" **PADJ1-L-F**
10" **PADJ1-M-F**
8" **PADJ1-S-F**

KENYAN QUILT



14" **PADJ2-XL-F**
12" **PADJ2-L-F**
10" **PADJ2-M-F**
8" **PADJ2-S-F**

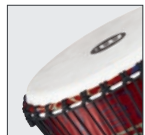

SYNTHETIC HEAD

1 ROPE TUNED TRAVEL SERIES DJEMBES, SYNTHETIC HEAD (PATENTED)

- SIZES**
- S:** 8" diameter, 16" tall
 - M:** 10" diameter, 20" tall
 - L:** 12" diameter, 24" tall
 - XL:** 14" diameter, 26" tall
- HTP ROPES**
- S:** 4 mm thickness, 20 runners
 - M:** 4 mm thickness, 25 runners
 - L:** 4 mm thickness, 30 runners
 - XL:** 5 mm thickness, 35 runners

MATERIALS Synthetic shell; Synthetic head

FEATURES 100% synthetic heads and shells are perfect for outdoor playing; Ultra light weight makes them easy to carry; Pre-stretched HTP nylon ropes; Produces sharp slaps and deep bass tones; Non-slip rubber bottom to protect the drum from scratches

- FINISHES**
- PADJ1:** Pharaoh's Script
 - PADJ2:** Kenyan Quilt
 - PADJ5:** Simbra
 - PADJ6:** Kanga Sarong
 - PADJ7:** Day of the Dead
 - PADJ8:** Galactic Blue Tie Dye



SYNTHETIC DJEMBES



2 JR. DJEMBES

SIZE 7" diameter, 12 1/2" tall
ROPE 14 runners
MATERIALS Synthetic shell; Synthetic head
FEATURES Grab-and-go for any occasion, indoors or outside; Compact size and lightweight shell; Pre-stretched ropes; Produces sharp slaps and deep bass tones; 100% synthetic head and shell are perfect for outdoor playing
COLOURS **B:** Blue
BK: Black
G: Green
O: Orange
R: Red
Y: Yellow

FINISHES **GB:** Galactic Blue Tie Dye
KQ: Kenyan Quilt
PS: Pharaoh's Script
SI: Simbra
TA: Twisted Amber
TD: Tie Dye

3 ROPE TUNED TRAVEL SERIES DJEMBES, GOATSKIN HEAD (PATENTED)

SIZES **S:** 8" diameter, 16" tall
M: 10" diameter, 20" tall
L: 12" diameter, 24" tall
XL: 14" diameter, 26" tall
HTP ROPES **S:** 4 mm thickness, 20 runners
M: 4 mm thickness, 25 runners
L: 4 mm thickness, 30 runners
XL: 5 mm thickness, 35 runners

MATERIALS Synthetic shell
PADJ1, PADJ2 Hand selected goatskin head
PADJ4 Black coloured hand selected goatskin head
FEATURES Goatskin heads give you authentic sound and feel; Synthetic shells are perfect for outdoor playing; Ultra light weight makes them easy to carry; Pre-stretched HTP nylon ropes; Produces sharp slaps and deep bass tones; Non-slip rubber bottom to protect the drum from scratches
FINISHES **PADJ1:** Pharaoh's Script
PADJ2: Kenyan Quilt
PADJ4: Phantom Black

JUMBO DJEMBES

1

DAY OF THE DEAD

NEW

14" **JD14DA-DH**
12" **JD12DA-DH**
10" **JD10DA-DH**

DESIGNER HEAD

NEW

14" **JD14SI-DH**
12" **JD12SI-DH**
10" **JD10SI-DH**

BARNWOOD

NEW

14" **JD14BW**
12" **JD12BW**
10" **JD10BW**

DAY OF THE DEAD

NEW

14" **JD14DA**
12" **JD12DA**
10" **JD10DA**

SIMBRA

NEW

14" **JD14SI**
12" **JD12SI**
10" **JD10SI**

- | | | |
|-------------------------------------------------------------------------------------------------------------------------------------------------------------------------------------------------------------------------------------------------------------------------------------------------------------------------------------------------------------------------------------------------------------------------------------------------------------------------------------------------------------------------------------------------------------------------------------------------------------------------|--------------------------------------------------------------------------------------------------------------------------------------------------------------------------------------------------------------------------------------------------------------------------------------------------------------------------------------------------------------------------------------------------------------------------------------------------|--------------------------------------------------------------------------------------------------------------------------------------------------------------------------------------------------------------------------------------------------------------------------------------------------------------------------------------------------------------------------------------------------------------------------|
| <p>1 JUMBO DJEMBES</p> <p>SIZES JD10: 10" diameter, 20 1/2" tall
JD12: 12" diameter, 24" tall
JD14: 14" diameter, 26" tall</p> <p>MATERIALS Synthetic shell
Synthetic head</p> <p>FEATURES Jumbo size for deep bass tone
100% all-weather synthetic shell and head
Easy to use mechanical tuning system
Lightweight construction to travel easily</p> <p>FINISHES BW: Barnwood
DA: Day of the Dead
DA-DH: Day of the Dead, designer head
SI: Simbra
SI-DH: Simbra, designer head</p> | <p>2 JUMBO DJEMBE SYNTHETIC HEADS</p> <p>SIZES HEAD-JD10: 10"
HEAD-JD12: 12"
HEAD-JD14: 14"</p> <p>MATERIALS Synthetic head</p> <p>FEATURES For the MEINL Jumbo Djembe
100% synthetic all-weather head</p> <p>FINISHES BK: Black leather cloth
DA: Day of the Dead
SI: Simbra
WH: White Fiberskin
Y: Yellow Fiberskin</p> | <p>3 COMMUNITY CONGAS</p> <p>SIZES TU10SI: 10" diameter, 25 1/2" tall
TU12SI: 12" diameter, 25 1/2" tall
TU14SI: 14" diameter, 25 1/2" tall</p> <p>MATERIALS Synthetic shell
Synthetic head</p> <p>FEATURES Great for drum circles and students
Warm open tones
Indoor/outdoor
Easy to play and tune</p> <p>FINISH SI: Simbra</p> |
|-------------------------------------------------------------------------------------------------------------------------------------------------------------------------------------------------------------------------------------------------------------------------------------------------------------------------------------------------------------------------------------------------------------------------------------------------------------------------------------------------------------------------------------------------------------------------------------------------------------------------|--------------------------------------------------------------------------------------------------------------------------------------------------------------------------------------------------------------------------------------------------------------------------------------------------------------------------------------------------------------------------------------------------------------------------------------------------|--------------------------------------------------------------------------------------------------------------------------------------------------------------------------------------------------------------------------------------------------------------------------------------------------------------------------------------------------------------------------------------------------------------------------|

COMMUNITY DRUMS



2 NEW NEW NEW NEW NEW

10" HEAD-JD10WH 10" HEAD-JD10Y 10" HEAD-JD10DA 10" HEAD-JD10SI 10" HEAD-JD10BK

12" HEAD-JD12WH 12" HEAD-JD12Y 12" HEAD-JD12DA 12" HEAD-JD12SI 12" HEAD-JD12BK

14" HEAD-JD14WH 14" HEAD-JD14Y 14" HEAD-JD14DA 14" HEAD-JD14SI 14" HEAD-JD14BK

NEW NEW NEW

3 NEW

SIMBRA

14" TU14SI 12" TU12SI 10" TU10SI

DJEMBS & COMMUNITY DRUMS

4 NEW

SIMBRA

12" TI12SI

5 NEW

SIMBRA

14" TIM14SI

6 STACKABLE FOR EASY STORAGE AND TRANSPORTATION CAN BE TAKEN OFF THE DRUM INSTANTLY WITHOUT ANY TUNING

BOOM SERIES SOFT SOUND SERIES

Set, 2 pcs. VR-SDSET-SH Set, 2 pcs. VR-SDSET-NH

4 COMMUNITY TIMBAU
 SIZE 12" diameter, 23 1/2" tall
 MATERIALS Synthetic shell
 Synthetic head
 FEATURES Great for drum circles and students
 Warm open tones
 Indoor/outdoor
 Easy to play and tune
 FINISH **SI:** Simbra

5 COMMUNITY TIMBA
 SIZE 14" diameter, 39 1/2" tall
 MATERIALS Synthetic shell
 Synthetic head
 FEATURES Great for drum circles and students
 Warm open tones
 Indoor/outdoor
 Easy to play and tune
 FINISH **SI:** Simbra

6 STACK DRUM SETS
 SIZES 9 1/2" diameter, 17 1/4" tall
 12" diameter, 24" tall
 MATERIALS Synthetic shell
SH: Synthetic head
NH: Napa head
 FEATURES Synthetic shell is perfect for outdoor playing; Stackable for easy storage and transportation; Non-slip rubber bottom; Great for any skill level or style
SH: Pre-tuned synthetic head for cutting sounds with sharp attack
NH: Pre-tuned Napa head creates softer, warmer sound

ALPINE SERIES DJEMBES

1

GALACTIC BLUE TIE DYE



12" **ADJ12-GB** 10" **ADJ10-GB**

DAY OF THE DEAD



12" **ADJ12-DA** 10" **ADJ10-DA**

2

PIEZO PICKUP AND VOLUME CONTROL



12" **PADJ12-BW**

KANGA SARONG



12" **ADJ12-KA** 10" **ADJ10-KA**

SIMBRA



12" **ADJ12-SI** 10" **ADJ10-SI**

BARNWOOD



12" **ADJ12-BW** 10" **ADJ10-BW**

1 ALPINE SERIES DJEMBES

SIZES **ADJ10:** 10" diameter, 20" tall
ADJ12: 12" diameter, 24" tall

MATERIALS Synthetic shell
Synthetic head

FEATURES Durable, synthetic head and shell
Ultra light weight
Mechanical tuning system
Perfect for travel and outdoor performance

FINISHES **BW:** Barnwood
DA: Day of the Dead
GB: Galactic Blue Tie Dye
KA: Kanga Sarong
SI: Simbra

2 PICKUP ALPINE SERIES DJEMBE

SIZE 12" diameter, 24" tall

MATERIALS Synthetic shell
Synthetic head

FEATURES 100% synthetic djembe; Piezo pickup and volume control; Mechanically tuned head; Great for outdoor performances

FINISH **BW:** Barnwood



POP OFF & 3-IN-1 DJEMBES



3

MAY BE PLAYED BY THEMSELVES AS A SMALL HAND DRUM

14" 12" 10" 9" 8" 14" 12" 10" 9" 8"

VR-POH14-SH VR-POH12-SH VR-POH10-SH VR-POH9-SH VR-POH8-SH VR-POH14-NH VR-POH12-NH VR-POH10-NH VR-POH9-NH VR-POH8-NH

SYNTHETIC DJEMBES

4

BOOM SERIES

CAN BE TAKEN OFF THE DRUM INSTANTLY WITHOUT ANY TUNING

14" x 26 1/4" VR-SDJPO14-SH 12" x 23" VR-SDJPO12-SH 10" x 19 1/2" VR-SDJPO10-SH 9" x 16 1/2" VR-SDJPO9-SH 8" x 16 1/4" VR-SDJPO8-SH

SOFT SOUND SERIES

14" x 26 1/4" VR-SDJPO14-NH 12" x 23" VR-SDJPO12-NH 10" x 19 1/2" VR-SDJPO10-NH 9" x 16 1/2" VR-SDJPO9-NH 8" x 16 1/4" VR-SDJPO8-NH

5

BOOM SERIES

Set, 3 pcs. VR-SDJSET-SH

THE POP OFF DJEMBE HEADS MAY BE PLAYED BY THEMSELVES AS A SMALL HAND DRUM

SOFT SOUND SERIES

Set, 3 pcs. VR-SDJSET-NH

STACKABLE FOR EASY STORAGE AND TRANSPORTATION

3 POP OFF HEADS

SIZES VR-POH8: 8" head diameter
VR-POH9: 9" head diameter
VR-POH10: 10" head diameter
VR-POH12: 12" head diameter
VR-POH14: 14" head diameter

MATERIALS SH: Synthetic head
NH: Napa head

FEATURES Available as Napa style (soft sound) or standard synthetic (sharp sounds)
Instantly take on or off your MEINL VivaRhythm® Pop Off Djembe
May be played by themselves as a small hand drum
Nylon-loop for easy removal
Pre-tuned

4 POP OFF DJEMBES

SIZES VR-SDJPO8: 8" head diameter, 16 1/4" height
VR-SDJPO9: 9" head diameter, 16 1/2" height
VR-SDJPO10: 10" head diameter, 19 1/2" height
VR-SDJPO12: 12" head diameter, 23" height
VR-SDJPO14: 14" head diameter, 26 1/4" height

MATERIALS Synthetic shell
SH: Synthetic head
NH: Napa head

FEATURES Synthetic shell is perfect for outdoor playing
Non-slip rubber bottom
Great for any skill level or style
SH: Removable, pre-tuned synthetic head for cutting sounds with sharp attack

NH: Removable, pre-tuned Napa head creates softer, warmer sound

5 3-IN-1 DJEMBES

SIZES 8" head diameter, 16 1/4" height
10" head diameter, 19 1/2" height
12" head diameter, 23" height

MATERIALS Synthetic shell
SH: Synthetic head
NH: Napa head

FEATURES Synthetic shell is perfect for outdoor playing
Non-slip rubber bottom
Great for any skill level or style
Stackable for easy storage and transportation
SH: Pre-tuned synthetic head for cutting sounds with sharp attack
NH: Pre-tuned Napa head creates softer, warmer sound

ROPE TUNED HEADLINER® SERIES WOOD DJEMBES



ROPE TUNED HEADLINER® SERIES WOOD DJEMBES 1 2 3 4

SIZES

- S:** 8" diameter, 15 3/4" tall
- M:** 10" diameter, 20" tall
- L:** 12" diameter, 24" tall
- XL:** 13" diameter, 25" tall

PP ROPES

- S:** 4 mm thickness, 16 runners
- M:** 4 mm thickness, 18 runners
- L:** 5 mm thickness, 20 runners
- XL:** 6 mm thickness, 24 runners

1 NILE SERIES

MATERIALS Mahogany Wood (*Swietenia macrophylla*)
Hand selected goatskin heads

FEATURES Carved from one solid piece of plantation grown Mahogany Wood
Pre-stretched PP nylon ropes
Hand carved shells

COLOUR Brown

2 BLACK RIVER SERIES

MATERIALS Mahogany Wood (*Swietenia macrophylla*)
Hand selected goatskin heads

FEATURES Carved from one solid piece of plantation grown Mahogany Wood
Pre-stretched PP nylon ropes
Hand carved shells

COLOUR Black

3 ARTIFACT SERIES

MATERIALS Mahogany Wood (*Swietenia macrophylla*)
Hand selected goatskin heads

FEATURES Carved from one solid piece of plantation grown Mahogany Wood
Pre-stretched PP nylon ropes
Hand carved shells

COLOUR Brown

4 CONGO SERIES

MATERIALS Mahogany Wood (*Swietenia macrophylla*)
Hand selected goatskin heads

FEATURES Carved from one solid piece of plantation grown Mahogany Wood
Pre-stretched PP nylon ropes
Hand carved shells
Ornamental carving

COLOUR Dark Brown

MINI & ROPE TUNED WOOD DJEMBES



1

Python Design, 4 1/2"
HDJ5-XXS

Dark Serpent Design, 4 1/2"
HDJ6-XXS

Gecko Design, 4 1/2"
HDJ7-XXS

Flower Design, 4 1/2"
HDJ8-XXS

2

BLACK COLOURED HAND SELECTED GOATSKIN HEADS

FIRE RHYTHM SERIES

13"
ADJ7-XL

12"
ADJ7-L

10"
ADJ7-M

EARTH RHYTHM SERIES

13", bundle with bag
ADJ3-XL+BAG

12", bundle with bag
ADJ3-L+BAG

10", bundle with bag
ADJ3-M+BAG

WATER RHYTHM SERIES

13", bundle with bag
ADJ2-XL+BAG

12", bundle with bag
ADJ2-L+BAG

10", bundle with bag
ADJ2-M+BAG

WOOD DJEMBES

1 AFRICAN STYLE MINI DJEMBES

SIZE 4 1/2" (4 1/4" - 4 3/4") diameter, 8" tall

PP ROPE 3 mm thickness, 10 runners

MATERIALS Mahogany Wood (*Swietenia macrophylla*)
Hand selected goatskin head

FEATURES Carved from one solid piece of plantation grown Mahogany Wood
High quality PP nylon rope
Hand painted shell

FINISHES **HDJ5:** Python Design
HDJ6: Dark Serpent Design
HDJ7: Gecko Design
HDJ8: Flower Design

2 ORIGINAL AFRICAN STYLE ROPE TUNED WOOD DJEMBES

SIZES **M:** 10" (9 1/4" - 10 1/4") diameter, 20" tall
L: 12" (10 3/4" - 12 1/4") diameter, 24" tall
XL: 13" (12 3/4" - 13 3/4") diameter, 25" tall

HTP ROPES **M:** 4 mm thickness, 25 runners
L: 4 mm thickness, 35 runners
XL: 5 mm thickness, 35 runners

MATERIALS Mahogany Wood (*Swietenia macrophylla*)
Hand selected goatskin heads

FEATURES Carved from one solid piece of plantation grown Mahogany Wood
Pre-stretched HTP nylon ropes
Hand carved shells
Ornamental carving

ADJ7
Black coloured hand selected goatskin heads
Coloured rope wrapping

INCLUDES **ADJ2, ADJ3**
Professional Djembe Bag made out of heavy-duty padded nylon

COLOURS **ADJ2:** Brown
ADJ3: Brown/Black
ADJ7: Black

PROFESSIONAL, ARTISAN & TONGO CARVED DJEMBES

1 SPECIAL "AFRICAN QUEEN" CARVING 





12" **PROADJ4-L** 10" **PROADJ4-M**

SPECIAL "VILLAGE" CARVING 



12" **PROADJ2-L** 10" **PROADJ2-M**

2 DELUXE CARVING 



14" **PROADJ3-XXL**

3 COLOURED ORNAMENTAL CARVING 



12" **AE-DJTC2-L**

4 

KES-01



5 

DJTH



STANDARD DJEMBE BAGS (SEE PAGE 101)



MSTDJB10 **MSTDJB12**

1 PROFESSIONAL AFRICAN STYLE DJEMBES
SIZES **M:** 10" (9 1/4" - 10 1/4") diameter, 20" tall
L: 12" (10 3/4" - 12 1/4") diameter, 24" tall
HTP ROPES **M:** 4 mm thickness, 25 runners
L: 4 mm thickness, 35 runners
MATERIALS Mahogany Wood (*Swietenia macrophylla*)
 Hand selected goatskin heads
FEATURES Carved from one solid piece of plantation grown Mahogany Wood;
 Pre-stretched HTP nylon ropes
PROADJ2: "Village" carving
PROADJ4: "African Queen" carving
COLOUR Brown

2 ARTISAN EDITION DJEMBE
SIZE 14" (13 3/4" - 15 1/4") diameter, 26" tall
HTP ROPE 5 mm thickness, 40 runners
MATERIALS Mahogany Wood (*Swietenia macrophylla*)
 Hand selected goatskin head

FEATURES Carved from one solid piece of plantation grown Mahogany Wood; Pre-stretched HTP nylon rope; Deluxe carving
COLOUR Brown

3 ARTISAN EDITION TONGO CARVED DJEMBE
SIZE 12" (10 3/4" - 12 1/4") diameter, 24" tall
HTP ROPE 5 mm thickness, 30 runners
MATERIALS Mahogany Wood (*Swietenia macrophylla*)
 Hand selected goatskin head
FEATURES Carved from one solid piece of plantation grown Mahogany Wood; Pre-stretched HTP nylon ropes; Hand carved shell; Coloured ornamental carving
COLOUR Brown

4 KESSING
SIZE Medium
MATERIAL Aluminum

FEATURES Provides a dry rattling accompaniment to the drum; Slides securely into the webbing and is removable

5 DJEMBE TUNING HAMMER
MATERIAL Baltic Birch (*Betula pendula*)
FEATURES Use to tighten the tension on rope tuned djembes; Great for on-the-spot tuning adjustments

6 HEADLINER® SERIES WOOD DJEMBES
SIZE 12 1/2" diameter, 25 1/4" tall
MATERIALS Siam Oak (*Hevea brasiliensis* Muell.-Arg.)
 Hand selected goatskin head
FEATURES 8 mm strong tuning lugs; 2.6 mm rounded rims; Original MEINL style tuning brackets; Black powder coated hardware; Sleek Hourglass shape for more comfort
INCLUDES Tuning key

HEADLINER® & FLOATUNE SERIES WOOD DJEMBES



WOOD DJEMBES

6 ORIGINAL MEINL STYLE TUNING BRACKETS

Vintage Wine Barrel, 12 1/2" **HDJ500VWB-M**

Natural, 12 1/2" **HDJ500NT**

7 FLOATUNE TUNING AVOIDS THE NEED TO DRILL THROUGH THE SHELL

Gold Amber Sunburst, 12" **DJW3GAB-M**

Natural, 12" **DJW3NT**

8 FLOATUNE TUNING SYSTEM

Zebra Finished Ash, 12" **DJW3ZFA-M**

9 DESIGNER DJEMBE STRAPS

Day of the Dead **MDJS1DA** Kanga Sarong **MDJS1KA** Kenyan Quilt **MDJS1KQ** Pharaoh's Script **MDJS1PS** Simbra **MDJS1SI**

10 PROFESSIONAL SHOULDER STRAP

MDJS2

COLOURS **NT:** Natural, high gloss
VWB-M: Vintage Wine Barrel, matte

7 FLOATUNE SERIES WOOD DJEMBES
SIZE 12" diameter, 24 1/4" tall
MATERIALS Siam Oak (*Hevea brasiliensis* Muell.-Arg.) True Skin Goat Head
FEATURES 8 mm strong tuning lugs; 3 mm rounded SSR-Rims; Easy tuning and comfortable change of heads; Rubber pads and lug placement offer perfect playing comfort; Floatune Tuning System; Chrome plated hardware
INCLUDES Accessory pouch L-shaped tuning key Tune Up Oil
COLOURS **GAB-M:** Gold Amber Sunburst, matte
NT: Natural, high gloss

8 FLOATUNE SERIES WOODCRAFT DJEMBE
SIZE 12" diameter, 24 1/4" tall
MATERIALS American White Ash (*Fraxinus americana* L.) True Skin Goat Head
FEATURES 8 mm strong tuning lugs; 3 mm rounded SSR-Rims; Easy tuning and comfortable change of heads; Rubber pads and lug placement offer perfect playing comfort; Floatune Tuning System; Chrome plated hardware
INCLUDES Accessory pouch L-shaped tuning key Tune Up Oil
COLOUR Zebra Finished Ash, matte

9 DESIGNER DJEMBE STRAPS
MATERIAL Heavy-duty nylon
FEATURES Holds your djembe in a secure playing position; For standing djembe players; Heavy-duty synthetic fabric that lasts; Adjustable webbed PP straps for a comfortable fit
COLOURS **DA:** Day of the Dead
KA: Kanga Sarong
KQ: Kenyan Quilt
PS: Pharaoh's Script
SI: Simbra

10 PROFESSIONAL SHOULDER STRAP
MATERIAL Heavy-duty nylon
FEATURES Holds any djembe or other drums in perfect playing position; Length adjustable; Adjustable shoulder padding; Quick change hook
COLOUR Black

JOURNEY & HEADLINER® BONGOS

1



Black, 6 1/2" & 7 1/2"
HB50BK



Ultimate Grey, 6 1/2" & 7 1/2"
HB50UG

NEW



Bright White, 6 1/2" & 7 1/2"
HB50WH



Flamingo Pink, 6 1/2" & 7 1/2"
HB50FP



Red, 6 1/2" & 7 1/2"
HB50R



Electric Coral, 6 1/2" & 7 1/2"
HB50EC



Creamsicle, 6 1/2" & 7 1/2"
HB50CS



Illuminating Yellow, 6 1/2" & 7 1/2"
HB50IY



Forest Green, 6 1/2" & 7 1/2"
HB50FG



Seafoam Green, 6 1/2" & 7 1/2"
HB50SF



Glacier Blue, 6 1/2" & 7 1/2"
HB50GB

2



Walnut Brown, 6 3/4" & 8"
HTB100WB-M

TRADITIONAL
TTR-RIM

3



Natural, 6 3/4" & 8"
HB100NT



Vintage Sunburst, 6 3/4" & 8"
HB100VSB



Wine Red Burst, 6 3/4" & 8"
HB100WRB



Vintage Wine Barrel, 6 3/4" & 8"
HB100VWB-M

1 JOURNEY SERIES HB50 BONGOS

SIZES 6 1/2" Macho & 7 1/2" Hembra
MATERIALS Molded ABS
Hand selected buffalo heads
FEATURES Black powder coated hardware
Rounded rims for playing comfort
INCLUDES Tuning key
COLOURS **BK:** Black
CS: Creamsicle
EC: Electric Coral
FG: Forest Green
FP: Flamingo Pink
GB: Glacier Blue
IY: Illuminating Yellow
R: Red
SF: Seafoam Green
UG: Ultimate Grey
WH: Bright White

HEADLINER® SERIES WOOD BONGOS

2 3
SIZES 6 3/4" Macho & 8" Hembra
MATERIALS Siam Oak (*Hevea brasiliensis* Muell.-Arg.)
Hand selected buffalo heads
FEATURES Black powder coated hardware
8 mm strong tuning lugs
Interior backing plates
INCLUDES Tuning key

2 HEADLINER® SERIES HTB100 WOOD BONGO

FEATURE 5 mm strong TTR-rims
COLOUR **WB-M:** Walnut Brown, matte

3 HEADLINER® SERIES HB100 WOOD BONGOS

FEATURES 2 mm rounded rims for playing comfort
COLOURS **NT:** Natural, high gloss
VSB: Vintage Sunburst, high gloss
VWB-M: Vintage Wine Barrel, matte
WRB: Wine Red Burst, high gloss

4 BONGO & PERCUSSION PACK

CONTAINS Journey Series HB50BK Bongo
Compact Foot Tambourine
Luis Conte Live Shaker
Classic Wood Claves

5 HEADLINER® SERIES HFB100 FIBERGLASS BONGO

SIZES 6 3/4" Macho & 8" Hembra
MATERIALS Premium fiberglass
Hand selected buffalo heads

FIBERGLASS, WOOD & MARATHON® BONGOS



4

Set, 4 pcs.
BPP-1

WITH JOURNEY
SERIES HB50BK BONGO

5

Black, 6 3/4" & 8"
HFB100BK

PREMIUM FIBERGLASS

6

Natural, 6 3/4" & 8"
WB200NT-CH

CHROME PLATED
ROUNDED SSR RIM

7

Natural, 6 3/4" & 8"
FWB200NT

GOLD TONE
ROUNDED SSR RIM

7

Natural, 6 3/4" & 8"
WB200NT-G

CHROME PLATED
ROUNDED SSR RIM

7

Super Natural, 6 3/4" & 8"
WB200SNT-M

CHROME PLATED
ROUNDED SSR RIM

7

Gold Amber Sunburst, 6 3/4" & 8"
FWB200GAB

CHROME PLATED
ROUNDED SSR RIM

8

Leopard Burl, 6 3/4" & 8"
FWB190LB

8

Amber Flame, 6 3/4" & 8"
FWB190AF

9

Natural, 6 3/4" & 8"
FWB190NT

9

Super Natural, 6 3/4" & 8"
FWB190SNT-M

9

Antique Tobacco Burst, 6 3/4" & 8"
FWB190ATB-M

FEATURES Black powder coated hardware
8 mm strong tuning lugs
2.6 mm rounded rims

INCLUDES Tuning key
COLOUR **BK:** Black

6 WB200 WOOD BONGOS

SIZES 6 3/4" Macho & 8" Hembra
MATERIALS Siam Oak (*Hevea brasiliensis* Muell.-Arg.)
Hand selected buffalo heads

FEATURES Solid woodblock connection; 8 mm strong tuning lugs; 2 mm rounded SSR-Rim
WB200NT-CH: Chrome plated hardware
WB200NT-G: Gold tone hardware
WB200SNT-M: Chrome plated hardware

INCLUDES Accessory pouch; L-shaped tuning key; Tune Up Oil

COLOURS **NT:** Natural, high gloss
SNT-M: Super Natural, matte

MARATHON® SERIES WOOD BONGOS

7 8 9

SIZES 6 3/4" Macho & 8" Hembra
MATERIALS Siam Oak (*Hevea brasiliensis* Muell.-Arg.)
Hand selected buffalo heads

FEATURES MEINL Free Ride Suspension System;
8 mm strong tuning lugs

INCLUDES Accessory pouch; L-shaped tuning key; Tune Up Oil

7 MARATHON® EXCLUSIVE SERIES FWB200 WOOD BONGOS

FEATURES Chrome plated hardware;
2 mm rounded SSR-Rims

COLOURS **GAB:** Gold Amber Sunburst, high gloss
NT: Natural, high gloss

8 MARATHON® DESIGNER SERIES FWB190 WOOD BONGOS

FEATURES Unique designs; Black powder coated hardware; 2.5 mm rounded SSR-Rims

COLOURS **AF:** Amber Flame, high gloss
LB: Leopard Burl, high gloss

9 MARATHON® SERIES FWB190 WOOD BONGOS

FEATURES Black powder coated hardware;
2 mm rounded SSR-Rims

COLOURS **ATB-M:** Antique Tobacco Burst, matte
NT: Natural, high gloss
SNT-M: Super Natural, matte

BONGO HEADS & ARTIST, WOODCRAFT,

1

REMO HEADS AVAILABLE

The REMO® R-Series Bongo Heads add more volume and resonance to your Bongo. These are available for bongos with this sign.



Fiberskyn®
RHEAD-7NT

Fiberskyn®
RHEAD-812NT

Nuskyn®
RHEAD-7NS

Nuskyn®
RHEAD-812NS

Black Calfskin Skyndeeep®
RHEAD-7BK

Black Calfskin Skyndeeep®
RHEAD-812BK

2

REMO HEADS AVAILABLE



Natural, 6 3/4" & 8"
LC300NT-M

TRADITIONAL TTR-RIM

3

REMO HEADS AVAILABLE



Chamchuri Wood, 7" & 8 1/2"
DG400CW

TRUE SKIN CALF HEADS

Chamchuri Wood, 7" & 8 1/2"
DGR400CW

REMO® FIBERSKYN® HEADS

4

REMO HEADS AVAILABLE



Vintage Black, 7" & 8 1/2"
WB400VBK-M

Vintage Brown, 7" & 8 1/2"
WB400VBR-M

Vintage Red, 7" & 8 1/2"
WB400VR-M

1 REMO® R-SERIES BONGO HEADS

SIZES **RHEAD-7:** 7" Macho
RHEAD-812: 8 1/2" Hembra

FIT FOR LC300, FFB400, FWB400, CS400, WB400, BWB400

FINISHES **BK:** Black Calfskin Skyndeeep®
NS: Nuskyn®
NT: Fiberskyn®

2 ARTIST SERIES LC300 WOOD BONGO LUIS CONTE

SIZES 6 3/4" Macho & 8" Hembra

MATERIALS Siam Oak (*Hevea brasiliensis* Muell.-Arg.) True Skin Cow Heads

FEATURES Solid woodblock connection; Black powder coated hardware; 8 mm strong tuning lugs; 5 mm traditional TTR-Rims

INCLUDES Accessory pouch; L-shaped tuning key; Tune Up Oil

COLOUR **NT-M:** Natural, matte

3 ARTIST SERIES WOOD BONGOS DIEGO GALÉ

SIZES 7" Macho & 8 1/2" Hembra

MATERIALS Chamchuri Wood
DG400CW: Hand selected cow heads
DGR400CW: REMO® Fiberskyn® Heads (For more volume and resonance)

FEATURES MEINL Free Ride Suspension System; Brushed nickel hardware; 8 mm strong tuning lugs; 3 mm rounded SSR-Rims; Resonance Shaping Area

COLOUR Natural, high gloss

WOODCRAFT & PROFESSIONAL SERIES WOOD BONGOS

4 5 6 7

FEATURES MEINL Free Ride Suspension System; Chrome plated hardware; 8 mm strong tuning lugs; Resonance Shaping Area

INCLUDES Accessory pouch; L-shaped tuning key; Tune Up Oil

4 WOODCRAFT SERIES WB400 WOOD BONGOS

SIZES 7" Macho & 8 1/2" Hembra

MATERIALS American White Ash (*Fraxinus americana* L.) True Skin Cow Heads

FEATURE 3 mm rounded SSR-Rims

COLOURS **VBK-M:** Vintage Black, matte
VBR-M: Vintage Brown, matte
VR-M: Vintage Red, matte

PROFESSIONAL, MINI & FIBERCRAFT BONGOS



5

REMO HEADS AVAILABLE

European Birch, 7" & 8 1/2"
BWB400

6

Antique Mahogany Burst, 7" & 9"
WB500AMB

Zebra Finished Ash, 7" & 9"
WB500ZFA-M

CHROME PLATED
5 MM TRADITIONAL TTR RIM



7

REMO HEADS AVAILABLE

Natural, 7" & 8 1/2"
FWB400NT

Brown Burl, 7" & 8 1/2"
FWB400BB

8

MINI!

Super Natural, 3 1/2" & 4 1/4"
FWB100SNT-M

Cherry Red, 7" & 8 1/2"
FWB400CR

Gold Amber Sunburst, 7" & 8 1/2"
FWB400GAB

9

REMO HEADS AVAILABLE

Black, 7" & 8 1/2"
FFB400BK

TRUE SKIN
COW HEADS

Black, 7" & 8 1/2"
FFBR400BK

REMO® BLACK
CALFSKIN
SKYNDDEEP® HEADS

PREMIUM FIBERGLASS

5 WOODCRAFT SERIES

BWB400 WOOD BONGO

SIZES 7" Macho & 8 1/2" Hembra
MATERIALS European Birch (*Betula pendula*)
Hand selected cow heads
FEATURES Natural finish European Birch shells;
3 mm rounded SSR-Rims
COLOUR Natural

6 WOODCRAFT SERIES

WB500 WOOD BONGOS

SIZES 7" Macho & 9" Hembra
MATERIALS American White Ash
(*Fraxinus americana* L.)
True Skin Cow Heads
FEATURE 5 mm traditional TTR-Rims
COLOURS **AMB**: Antique Mahogany Burst, high gloss
ZFA-M: Zebra Finished Ash, matte

7 PROFESSIONAL SERIES

FWB400 WOOD BONGOS

SIZES 7" Macho & 8 1/2" Hembra
MATERIALS Siam Oak (*Hevea brasiliensis* Muell.-Arg.)
True Skin Cow Heads
FEATURE 3 mm rounded SSR-Rims
COLOURS **BB**: Brown Burl, high gloss
CR: Cherry Red, high gloss
GAB: Gold Amber Sunburst, high gloss
NT: Natural, high gloss

8 FWB100 MINI WOOD BONGO

SIZES 3 1/2" Macho & 4 1/4" Hembra
MATERIALS Siam Oak (*Hevea brasiliensis* Muell.-Arg.)
True Skin Buffalo Heads
FEATURES MEINL Free Ride Suspension System;
Chrome plated hardware;
2 mm rounded SSR-Rims
INCLUDES Tuning key
COLOUR **SNT-M**: Super Natural, matte

9 FIBERCRAFT SERIES FIBERGLASS BONGOS

SIZES 7" Macho & 8 1/2" Hembra
MATERIALS Premium fiberglass
FFB400BK: True Skin Cow Heads
FFBR400BK: REMO® Black Calfskin
Skyndeeep® Heads (For more volume
and resonance)
FEATURES MEINL Free Ride Suspension System;
Chrome plated hardware; 8 mm strong
tuning lugs; 3 mm rounded SSR-Rims;
Resonance Shaping Area
INCLUDES Accessory pouch; L-shaped tuning key;
Tune Up Oil
COLOUR **BK**: Black

CONGA HEADS & MINI CONGAS

1



The REMO® Symmetry Conga Heads add more volume and resonance to your Conga. These are available for congas with this sign.



Black Calfskin Skyndeeep® **RHEAD-11BK** Black Calfskin Skyndeeep® **RHEAD-1134BK** Black Calfskin Skyndeeep® **RHEAD-1212BK**



Black Calfskin Skyndeeep® **RTHEAD-11BK** Black Calfskin Skyndeeep® **RTHEAD-1134BK** Black Calfskin Skyndeeep® **RTHEAD-1212BK**



Fiberskyn® **RHEAD-11NT** Fiberskyn® **RHEAD-1134NT** Fiberskyn® **RHEAD-1212NT**



Nuskyn® **RTHEAD-11NS** Nuskyn® **RTHEAD-1134NS** Nuskyn® **RTHEAD-1212NS**

2



Natural, 4 1/2" **MC100NT**

Vintage Wine Barrel, 4 1/2" **MC100VWB**

Wine Red, 4 1/2" **MC100WR**

3



CONGA-SAVER8 **CONGA-SAVER10**

4

COMES IN A SET OF 4



Set **MCR-BK**

5

FITS UNDER ANY CONGA



CSP

1 REMO® SYMMETRY CONGA HEADS

SIZES **RHEAD-11:** 11" Quinto; SSR-Rim
RHEAD-1134: 11 3/4" Conga; SSR-Rim
RHEAD-1212: 12 1/2" Tumba; SSR-Rim
RTHEAD-11: 11" Quinto; TTR-Rim
RTHEAD-1134: 11 3/4" Conga; TTR-Rim
RTHEAD-1212: 12 1/2" Tumba; TTR-Rim
FIT FOR **RHEAD:** MCC, MEC, MP, FC, MSA, WKT, WCO, BWC
RTHEAD: LC
FINISHES **BK:** Black Calfskin Skyndeeep®
NS: Nuskyn®
NT: Fiberskyn®

2 MINI CONGAS

SIZE 4 1/2" wide, 11" tall
MATERIALS Siam Oak (*Hevea brasiliensis* Muell.-Arg.) Buffalo skin heads
FEATURES Contains every feature of a regular MEINL conga, at 2/5 the size Tunable buffalo skin head with 4 chrome lugs and rounded rim Great for spontaneous jam sessions or drum circles
COLOURS **NT:** Natural
VWB: Vintage Wine Barrel
WR: Wine Red

3 CONGA SAVERS

SIZES **CONGA-SAVER8:** for 8 mm tuning lugs
CONGA-SAVER10: for 10 mm tuning lugs
FEATURES Placed over the conga lugs to prevent them from damaging and scratching the shell Conga remains fully tunable
PATENT MEINL Conga Saver (TH, US patent)

4 CONGA RISERS

MATERIAL Sturdy rubber
FEATURES Raise your drums off the floor to allow maximum sound projection Provide a stable base on any surface Come in a set of four Flexible construction
COLOUR **BK:** Black

WOODCRAFT SERIES CONGAS



6

REMO
HEADS
AVAILABLE

VINTAGE BLACK

VINTAGE BROWN



11"
WCO11VBK-M

11 3/4"
WCO1134VBK-M

12 1/2"
WCO1212VBK-M



11"
WCO11VBR-M

11 3/4"
WCO1134VBR-M

12 1/2"
WCO1212VBR-M

VINTAGE RED



11"
WCO11VR-M

11 3/4"
WCO1134VR-M

12 1/2"
WCO1212VR-M

PROFESSIONAL CONGA DOUBLE
STAND WITH WHEELS
(SEE PAGE 90)



TMPDS

PROFESSIONAL CONGA STAND
WITH WHEELS
(SEE PAGE 91)



TMPC

CONGAS

5 CONGA SOUND PLATE

SIZE 13 1/4"
MATERIAL Siam Oak (*Hevea brasiliensis* Muell.-Arg.)
FEATURE Provides a hard sound reflective surface under your conga

6 WOODCRAFT SERIES WCO CONGAS

SIZES **WCO11:** 11" Quinto, 30" tall
WCO1134: 11 3/4" Conga, 30" tall
WCO1212: 12 1/2" Tumba, 30" tall
MATERIALS Three ply American White Ash (*Fraxinus americana* L.)
True Skin Buffalo Heads
FEATURES 10 mm strong tuning lugs
4 mm rounded SSR-Rims
Chrome plated hardware
INCLUDES MEINL Conga Saver (TH, US patent)
MEINL Conga Handle
MEINL Soundpads
Accessory pouch
L-shaped tuning key
Tune Up Oil
COLOURS **VBK-M:** Vintage Black
VBR-M: Vintage Brown
VR-M: Vintage Red
FINISH Matte

WOODCRAFT TRADITIONAL, FLOATUNE SERIES CONGAS

1

ZEBRA FINISHED ASH



11"
WC11ZFA-M

11 3/4"
WC1134ZFA-M

12 1/2"
WC1212ZFA-M

PROFESSIONAL CONGA BAGS
(SEE PAGE 101)



MCOB-11

MCOB-1134

MCOB-1212

2

NATURAL



10"
FL10NT

11"
FL11NT

12"
FL12NT

13"
FL13NT

THE FLOATUNE TUNING SYSTEM
ALLOWS THE SHELL TO
VIBRATE FREELY



1 WOODCRAFT TRADITIONAL SERIES CONGAS

SIZES WC11: 11" Quinto, 30" tall
WC1134: 11 3/4" Conga, 30" tall
WC1212: 12 1/2" Tumba, 30" tall

MATERIALS Three ply American White Ash (*Fraxinus americana* L.)
True Skin Buffalo Heads

FEATURES 10 mm strong tuning lugs
5 mm traditional TTR-Rims
Chrome plated hardware

INCLUDES MEINL Conga Saver (TH, US patent)
MEINL Conga Handle
MEINL Soundpads
Accessory pouch
L-shaped tuning key
Tune Up Oil

COLOUR Zebra Finished Ash
FINISH Matte

2 FLOATUNE SERIES CONGAS

SIZES FL10: 10" Nino, 30" tall
FL11: 11" Quinto, 30" tall
FL12: 12" Conga, 30" tall
FL13: 13" Tumba, 30" tall

MATERIALS Two ply Siam Oak (*Hevea brasiliensis* Muell.-Arg.)
True Skin Buffalo Heads

FEATURES Floatune Tuning System
10 mm strong tuning lugs
4 mm rounded SSR-Rims
Chrome plated hardware

INCLUDES MEINL Conga Saver (TH, US patent)
MEINL Conga Handle
MEINL Soundpads
Accessory pouch
L-shaped tuning key
Tune Up Oil

COLOUR Natural
FINISH High gloss

PROFESSIONAL & FIBERCRAFT SERIES CONGAS



1  NATURAL BROWN BURL



11" **MP11NT** 11 3/4" **MP1134NT** 12 1/2" **MP1212NT** 11" **MP11BB** 11 3/4" **MP1134BB** 12 1/2" **MP1212BB**

CONGAS

2  TRUE SKIN BUFFALO HEADS REMO® BLACK CALFSKIN SKYNDDEEP® HEADS



11" **FC11BK** 11 3/4" **FC1134BK** 12 1/2" **FC1212BK** 11" **FCR11BK** 11 3/4" **FCR1134BK** 12 1/2" **FCR1212BK**

1 PROFESSIONAL SERIES CONGAS

- SIZES** **MP11:** 11" Quinto, 30" tall
MP1134: 11 3/4" Conga, 30" tall
MP1212: 12 1/2" Tumba, 30" tall
- MATERIALS** Two ply Siam Oak
 (Hevea brasiliensis Muell.-Arg.)
 True Skin Buffalo Heads
- FEATURES** 10 mm strong tuning lugs
 4 mm rounded SSR-Rims
 Chrome plated hardware
- INCLUDES** MEINL Conga Saver (TH, US patent)
 MEINL Conga Handle
 MEINL Soundpads
 Accessory pouch
 L-shaped tuning key
 Tune Up Oil
- COLOURS** **BB:** Brown Burl
NT: Natural
- FINISH** High gloss

2 FIBERCRAFT SERIES CONGAS

- SIZES** **FC(R)11:** 11" Quinto, 30" tall
FC(R)1134: 11 3/4" Conga, 30" tall
FC(R)1212: 12 1/2" Tumba, 30" tall
- MATERIALS** Premium fiberglass
FC: True Skin Buffalo Heads
FCR: REMO® Black Calfskin Skynddeep® Heads (For more volume and resonance)
- FEATURES** 10 mm strong tuning lugs
 4 mm rounded SSR-Rims
 Chrome plated hardware
- INCLUDES** MEINL Conga Saver (TH, US patent)
 MEINL Conga Handle
 MEINL Soundpads
 Accessory pouch
 L-shaped tuning key
 Tune Up Oil
- COLOUR** **BK:** Black

REMO® SYMMETRY CONGA HEADS (SEE PAGE 64)



The REMO® Symmetry Conga Heads add more volume and resonance to your Conga. These are available for congas with this sign.



ARTIST SERIES CONGAS

1 **REMO HEADS AVAILABLE**

TRUE SKIN BUFFALO HEADS

LCR



11" **LC11NT-M** 11 3/4" **LC1134NT-M** 12 1/2" **LC1212NT-M**

REMO® NUSKYN® HEADS



11" **LCR11NT-M** 11 3/4" **LCR1134NT-M** 12 1/2" **LCR1212NT-M**

2 **REMO HEADS AVAILABLE**

TRUE SKIN BUFFALO HEADS

"MONGO" Santamaria



11" **MSA11AWA** 11 3/4" **MSA1134AWA** 12 1/2" **MSA1212AWA**

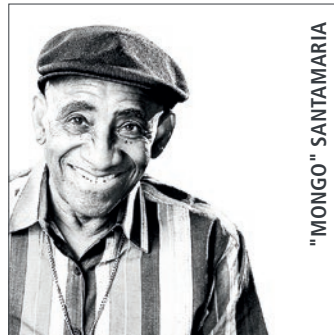

1 ARTIST SERIES CONGAS LUIS CONTE

SIZES **LC(R)11:** 11" Quinto, 30" tall
LC(R)1134: 11 3/4" Conga, 30" tall
LC(R)1212: 12 1/2" Tumba, 30" tall

MATERIALS Two ply Siam Oak
(Hevea brasiliensis Muell.-Arg.)
LC: True Skin Buffalo Heads
LCR: REMO® Nuskyn® Heads
 (For more volume and resonance)

FEATURES 8 mm strong tuning lugs
 5 mm traditional TTR-Rims
 Black powder coated hardware

INCLUDES MEINL Conga Saver (TH, US patent)
 MEINL Soundpads
 Accessory pouch
 L-shaped tuning key
 Tune Up Oil

COLOUR **NT:** Natural

FINISH Matte

2 ARTIST SERIES CONGAS

RAMON "MONGO" SANTAMARIA

SIZES **MSA11:** 11" Quinto, 30" tall
MSA1134: 11 3/4" Conga, 30" tall
MSA1212: 12 1/2" Tumba, 30" tall

MATERIALS Two ply American White Ash
(Fraxinus americana L.)
 True Skin Buffalo Heads

FEATURES 10 mm strong tuning lugs
 4 mm rounded SSR-Rims
 Gold tone hardware

INCLUDES MEINL Conga Saver (TH, US patent)
 MEINL Soundpads
 Accessory pouch
 L-shaped tuning key
 Tune Up Oil

COLOUR **AWA:** American White Ash

FINISH High gloss

3 **REMO HEADS AVAILABLE**

HAND SELECTED MULESKIN HEADS

Kachiro Thompson

11" **WKT11NT** 11 3/4" **WKT1134NT** 12 1/2" **WKT1212NT**

REMO® BLACK CALFSKIN SKYNDDEEP® HEADS

11" **WKTR11NT** 11 3/4" **WKTR1134NT** 12 1/2" **WKTR1212NT**

4 **REMO HEADS AVAILABLE**

HAND SELECTED BUFFALO HEADS

Diego Galé

11" **DG11CW** 11 3/4" **DG1134CW** 12 1/2" **DG1212CW**

REMO® FIBERSKYN® HEADS

11" **DGR11CW** 11 3/4" **DGR1134CW** 12 1/2" **DGR1212CW**

3 ARTIST SERIES CONGAS
WILLIAM "KACHIRO" THOMPSON

SIZES **WKT(R)11:** 11" Quinto, 30" tall
WKT(R)1134: 11 3/4" Conga, 30" tall
WKT(R)1212: 12 1/2" Tumba, 30" tall

MATERIALS Three ply Siam Oak
(Hevea brasiliensis Muell.-Arg.)
WKT: Hand selected muleskin heads
WKTR: REMO® Black Calfskin Skynddeep® Heads (For more volume and resonance)

FEATURES 10 mm strong tuning lugs
 4 mm rounded SSR-Rims
 Gold tone hardware

INCLUDES MEINL Conga Saver (TH, US patent)
 MEINL Conga Handle
 MEINL Soundpads
 Accessory pouch

COLOUR FINISH **NT:** Natural
 High gloss

4 ARTIST SERIES CONGAS DIEGO GALÉ

SIZES **DG(R)11:** 11" Quinto, 30" tall
DG(R)1134: 11 3/4" Conga, 30" tall
DG(R)1212: 12 1/2" Tumba, 30" tall

MATERIALS Two ply Chamchuri Wood
DG: Hand selected buffalo heads
DGR: REMO® Fiberskyn® Heads (For more volume and resonance)

FEATURES 10 mm strong tuning lugs
 4 mm rounded SSR-Rims
 Brushed nickel hardware

INCLUDES MEINL Conga Saver (TH, US patent)
 MEINL Conga Handle
 MEINL Soundpads
 Accessory pouch
 L-shaped tuning key
 Tune Up Oil

COLOUR FINISH **CW:** Chamchuri Wood
 High gloss

REMO® SYMMETRY CONGA HEADS
 (SEE PAGE 64)

The REMO® Symmetry Conga Heads add more volume and resonance to your Conga. These are available for congas with this sign.



MARATHON® EXCLUSIVE & DESIGNER SERIES CONGAS



11"
MEC11NT-CH

11 3/4"
MEC1134NT-CH

12 1/2"
MEC1212NT-CH

11"
MECR11NT-CH

11 3/4"
MECR1134NT-CH

12 1/2"
MECR1212NT-CH



11"
MEC11NT-G

11 3/4"
MEC1134NT-G

12 1/2"
MEC1212NT-G



11"
MCC11LB

11 3/4"
MCC1134LB

12 1/2"
MCC1212LB

1 MARATHON® EXCLUSIVE SERIES CONGAS

SIZES **MEC(R)11:** 11" Quinto, 30" tall
MEC(R)1134: 11 3/4" Conga, 30" tall
MEC(R)1212: 12 1/2" Tumba, 30" tall

MATERIALS Two ply Siam Oak
(*Hevea brasiliensis* Muell.-Arg.)

MEC: True Skin Buffalo Heads

MECR: REMO® Fiberskyn® Heads
(For more volume and resonance)

FEATURES 8 mm strong tuning lugs
2.6 mm rounded SSR-Rims

CH: Chrome plated hardware

G: Gold tone hardware

INCLUDES Steely II Conga Stand (patented)
MEINL Conga Saver (TH, US patent)
MEINL Conga Handle
MEINL Sound Pads
Accessory pouch
L-shaped tuning key
Tune Up Oil

COLOUR **NT:** Natural
FINISH High gloss
PATENTS Steely-II patents:
L-shaped leg and metal spike attachment
(DE, TH, US patent)
U-shaped notch (US patent)
Ergonomic arched rubber bracing
(CN, DE, TH, US patent)
Notches for quick height adjustability
(DE patent)

2 MARATHON® DESIGNER SERIES CONGAS

SIZES **MCC11:** 11" Quinto, 30" tall
MCC1134: 11 3/4" Conga, 30" tall
MCC1212: 12 1/2" Tumba, 30" tall

MATERIALS Two ply Siam Oak
(*Hevea brasiliensis* Muell.-Arg.)
True Skin Buffalo Heads

FEATURES 8 mm strong tuning lugs
2.6 mm rounded SSR-Rims
Black powder coated hardware
INCLUDES Steely II Conga Stand (patented)
MEINL Conga Saver (TH, US patent)
Accessory pouch
L-shaped tuning key
Tune Up Oil

COLOUR **LB:** Leopard Burl
FINISH High gloss
PATENTS Steely-II patents:
L-shaped leg and metal spike attachment
(DE, TH, US patent)
U-shaped notch (US patent)
Ergonomic arched rubber bracing
(CN, DE, TH, US patent)
Notches for quick height adjustability
(DE patent)

MARATHON® CLASSIC SERIES CONGAS



3

REMO HEADS AVAILABLE



NATURAL

STEELY II CONGA STAND

ERGONOMIC ARCHED RUBBER BRACING

U-SHAPED NOTCH

NOTCHES FOR QUICK HEIGHT ADJUSTABILITY

L-SHAPED LEG

METAL SPIKE ATTACHMENT



CONGAS

11"
MCC11NT

11 3/4"
MCC1134NT

12 1/2"
MCC1212NT



SUPER NATURAL



COFFEE BURST

11"
MCC11SNT-M

11 3/4"
MCC1134SNT-M

12 1/2"
MCC1212SNT-M

11"
MCC11CB

11 3/4"
MCC1134CB

12 1/2"
MCC1212CB

3 MARATHON® CLASSIC SERIES CONGAS

SIZES **MCC11:** 11" Quinto, 30" tall
MCC1134: 11 3/4" Conga, 30" tall
MCC1212: 12 1/2" Tumba, 30" tall

MATERIALS Two ply Siam Oak
(*Hevea brasiliensis* Muell.-Arg.)
True Skin Buffalo Heads

FEATURES 8 mm strong tuning lugs
2.6 mm rounded SSR-Rims
Black powder coated hardware

INCLUDES Steely II Conga Stand (patented)
MEINL Conga Saver (TH, US patent)
Accessory pouch
L-shaped tuning key
Tune Up Oil

COLOURS **CB:** Coffee Burst, high gloss
NT: Natural, high gloss
SNT-M: Super Natural, matte

PATENTS

Steely-II patents:
L-shaped leg and metal spike attachment (DE, TH, US patent)
U-shaped notch (US patent)
Ergonomic arched rubber bracing (CN, DE, TH, US patent)
Notches for quick height adjustability (DE patent)

REMO® SYMMETRY CONGA HEADS (SEE PAGE 64)



The REMO® Symmetry Conga Heads add more volume and resonance to your Conga. These are available for congas with this sign.



HEADLINER® & TRADITIONAL SERIES CONGAS



<p>1 HEADLINER® SERIES CONGAS</p> <p>SIZES HC10: 10" Nino, 28" tall HC11: 11" Quinto, 28" tall HC12: 12" Conga, 28" tall</p> <p>MATERIALS Siam Oak (<i>Hevea brasiliensis</i> Muell.-Arg.) Hand selected buffalo heads</p> <p>FEATURES 8 mm strong tuning lugs Original MEINL style tuning brackets 2 mm rounded rims Black powder coated hardware</p> <p>INCLUDES Height adjustable basket stands (patented) with quick set up system Tuning key</p> <p>COLOURS PBK-M: Phantom Black SNT-M: Super Natural VWB-M: Vintage Wine Barrel</p> <p>FINISH Matte</p>	<p>PATENTS</p>	<p>Basket stand patents: Ergo arched rubber bracing (CN, DE, TH, US patent) U-shaped notch (US patent) L-shaped leg (DE patent)</p>	<p>2 HEADLINER® TRADITIONAL SERIES CONGAS</p> <p>SIZES HTC10: 10" Nino, 28" tall HTC11: 11" Quinto, 28" tall HTC12: 12" Conga, 28" tall</p> <p>MATERIALS Siam Oak (<i>Hevea brasiliensis</i> Muell.-Arg.) Hand selected buffalo heads</p> <p>FEATURES 8 mm strong tuning lugs Original MEINL style tuning brackets 5 mm traditional TTR-Rims Black powder coated hardware</p> <p>INCLUDES Height adjustable basket stands (patented) with quick set up system Tuning key</p> <p>COLOUR WB-M: Walnut Brown</p> <p>FINISH Matte</p> <p>PATENTS Basket stand patents: Ergo arched rubber bracing (CN, DE, TH, US patent) U-shaped notch (US patent) L-shaped leg (DE patent)</p>
-----------------------------------------------------------------------------------------------------------------------------------------------------------------------------------------------------------------------------------------------------------------------------------------------------------------------------------------------------------------------------------------------------------------------------------------------------------------------------------------------------------------------------------------------------------------------------------------------------------------------------------------------------------------------------------------------------------------------------------------------	-----------------------	----------------------------------------------------------------------------------------------------------------------------------------------------------------------------	-------------------------------------------------------------------------------------------------------------------------------------------------------------------------------------------------------------------------------------------------------------------------------------------------------------------------------------------------------------------------------------------------------------------------------------------------------------------------------------------------------------------------------------------------------------------------------------------------------------------------------------------------------------------------------------------------------------------------------------------------------------------------------------------------------------------------------------------------------------------------------------

HEADLINER® SERIES CONGA SETS



3



Set, 10" & 11"
HC555NT



Set, 11" & 12"
HC512NT

NATURAL



Set, 10" & 11"
HC555VSB

VINTAGE SUNBURST



Set, 10" & 11"
HC888NT

THE BONGO MOUNT IS EASY MOUNTABLE ON OUR CONGA DOUBLE STANDS (SEE PAGE 90)



THBM



Set, 11" & 12"
HC512VSB



Set, 11" & 12"
HC812NT



Set, 10" & 11"
HC888VSB



Set, 11" & 12"
HC812VSB

3 HEADLINER® SERIES CONGA SETS

- SIZES** **HC555, HC888:**
10" Nino & 11" Quinto, 28" tall
HC512, HC812:
11" Quinto & 12" Conga, 28" tall
- MATERIALS** Siam Oak (*Hevea brasiliensis* Muell.-Arg.)
Hand selected buffalo heads
- FEATURES** 8 mm strong tuning lugs
Original MEINL style tuning brackets
2 mm rounded rims
Black powder coated hardware
- INCLUDES** Tuning key
HC555, HC512: Height adjustable basket stands (patented) with quick set up system
HC888, HC812: Height adjustable double braced tripod stand
- COLOURS** **NT:** Natural
VSB: Vintage Sunburst
- FINISH** High gloss

- PATENTS** Basket stand patents:
Ergo arched rubber bracing (CN, DE, TH, US patent)
U-shaped notch (US patent)
L-shaped leg (DE patent)

CONGAS

TIMBALES HEADS, TIMBALES,

1 DESIGNED FOR A UNIQUE LOOK

15" **TBLH15BK** 14" **TBLH14BK** 13" **TBLH13BK** 10" **TBLH10BK** 8" **TBLH8BK**

2

Chrome,
13" & 14"
HT1314CH

3 NEW

Chrome,
14" & 15"
MTS1415CH

Brass,
14" & 15"
MTS1415B

Black nickel,
14" & 15"
MTS1415BN

Antique Finish,
14" & 15"
MTS1415RR-M

NEW

4

Black powder coated
steel, 14" & 15"
MTT1415BK

**PROFESSIONAL TIMBALES BAG
(SEE PAGE 102)**

MTB

1 TIMBALES HEADS

SIZES **TBLH8BK:** 8" (Mini Timbales Head)
TBLH10BK: 10" (Mini Timbales Head)
TBLH13BK: 13"
TBLH14BK: 14"
TBLH15BK: 15"

MATERIAL Synthetic head

FEATURES Cutting and clean tone with effortless response; Extremely durable

COLOUR Black

2 HEADLINER® SERIES TIMBALES (PATENTED)

SIZES 13" & 14"

MATERIAL Steel

FEATURES Logo applied from underneath the head (CN, TH, US patent); Two worked-in flanges

INCLUDES Height adjustable tilting double braced tripod stand; Tuning key; Wrench; Cowbell holder

FINISH Chrome

3 MARATHON® SERIES TIMBALES (PATENTED)

SIZES 14" & 15", 6.5" deep

MATERIAL Steel

FEATURES Two worked-in flanges; Heavy-duty style brackets; Logo applied from underneath the head (CN, TH, US patent)

INCLUDES Adjustable cowbell holder; Height adjustable tilting double braced tripod stand; Accessory pouch; L-shaped tuning key; Tune Up Oil

FINISHES **B:** Brass
BN: Black nickel
CH: Chrome
RR-M: Antique Finish, matte

4 MARATHON® SERIES TURBO TIMBALES (PATENTED)

SIZES 14" & 15", 10" deep

MATERIAL Black powder coated steel

FEATURES Three worked-in flanges; Heavy-duty style brackets; Logo applied from underneath the head (CN, TH, US patent)

INCLUDES Adjustable cowbell holder; Height adjustable tilting double braced tripod stand; Accessory pouch; L-shaped tuning key; Tune Up oil

COLOUR **BK:** Black

ARTIST SERIES TIMBALES (PATENTED)

5 6 7

SIZES 14" & 15"

FEATURE Logo applied from underneath the head (CN, TH, US patent)

INCLUDES Adjustable cowbell holder; Accessory pouch; L-shaped tuning key; Tune Up Oil

HAND-BALE & COMPACT SNARE DRUMS



TIMBALES

5

Antique bronze,
14" & 15"
AV1ABR

6

Solid brass,
14" & 15"
LC1BRASS

Stainless steel,
14" & 15"
LC1STS

7

Solid brass,
14" & 15"
DG1415

8 SPECIAL DESIGNED RIM

Black powder coated steel, 13"
MHT13BK

9 CHATTER-FREE "OFF" POSITION

Black powder coated steel, 8"
MDST8BK

Black powder coated steel, 10"
MDST10BK

10

Chrome, 8" & 10"
MIT810CH

Chrome, 13"
MDT13CH

11 NEW

Maple, 10"
MPCSS

12 NEW

Maple, 10"
MPJS

5 ARTIST SERIES TIMBALES AMADITO VALDÉS

MATERIAL Steel
FEATURES Two worked-in flanges; Floatune Tuning System
INCLUDES Height adjustable tilting double braced tripod stand
COLOUR Antique bronze

6 ARTIST SERIES TIMBALES LUIS CONTE

MATERIALS **LC1BRASS**: Solid brass
LC1STS: Stainless steel
FEATURES Two worked-in flanges; Cuban style flared out bottom edge
INCLUDES Height adjustable tilting double braced tripod stand

7 ARTIST SERIES TIMBALES DIEGO GALÉ

MATERIAL Solid brass
FEATURE Classic Timbales shape and look
INCLUDES Professional Timbale Stand

8 ARTIST SERIES HAND-BALE TAKU HIRANO (PATENTED)

SIZE 13"
MATERIAL Black powder coated steel
FEATURE Logo applied from underneath the head (CN, TH, US patent)
INCLUDES L-shaped tuning key; Tune Up Oil
COLOUR **BK**: Black, high gloss

9 DRUMMER SNARE TIMBALES (PATENTED)

SIZES 8", 10"
MATERIAL Black powder coated steel
FEATURES Quick snare on/off system; Chatter-free "off" position; Logo applied from underneath the head (CN, TH, US patent)
INCLUDES L-shaped tuning key; Tune Up Oil
COLOUR **BK**: Black

10 DRUMMER TIMBALE & MINI TIMBALES (PATENTED)

SIZES **MDT13CH**: 13" (Drummer Timbale)
MIT810CH: 8" & 10" (Mini Timbales)
MATERIAL Steel
FEATURE Logo applied from underneath the head (CN, TH, US patent)
INCLUDES L-shaped tuning key; Tune Up Oil

11 COMPACT SIDE SNARE DRUM

SIZE 10", 3.5" deep
MATERIAL Maple
COLOUR Black

12 COMPACT JINGLE SNARE DRUM

SIZE 10", 4.5" deep
MATERIALS Maple shell
Stainless steel jingles
COLOUR Black

MINI & STANDARD DARBUKAS



1 MINI DARBUKAS

SIZE 4 1/4" diameter, 7 3/4" tall
MATERIALS Aluminum shell; All-weather synthetic head
FEATURES Fun to play and easy to carry; Great gift idea
HE-050: Plain shell
HE-051: Hand hammered shell
HE-052: Hand engraved shell
HE-053: Lacquered shell
INCLUDES Tuning key

2 COPPER DARBUKAS, HAND ENGRAVED

SIZES **HE-204:** 7 1/2" diameter, 14 3/4" tall
HE-205: 7 7/8" diameter, 15 1/2" tall
MATERIALS Copper shell; Natural rawhide
FEATURE Hand engraved shell
INCLUDES Tuning key

3 COPPER DARBUKAS, BRASS PLATED, HAND HAMMERED

SIZES **HE-214:** 7 1/2" diameter, 14 3/4" tall
HE-215: 7 7/8" diameter, 15 1/2" tall
MATERIALS Copper shell; Synthetic head
INCLUDES Tuning key

4 ALUMINUM DARBUKAS, HAND ENGRAVED

SIZES **HE-122:** 6 1/2" diameter, 12 3/4" tall
HE-124: 8" diameter, 14 1/2" tall
MATERIALS Aluminum shell; Synthetic head
INCLUDES Tuning key

5 ALUMINUM JINGLE DARBUKAS, HAND HAMMERED

SIZES **HE-314:** 8" diameter, 14 1/2" tall
HE-315: 8 1/4" diameter, 16" tall
MATERIALS Aluminum shell; Synthetic head
FEATURES Built-in jingles; Hand hammered shell
INCLUDES Tuning key

6 ALUMINUM DARBUKAS, HAND HAMMERED

SIZES **HE-110:** 5 1/3" diameter, 9 1/4" tall
HE-111: 5 7/8" diameter, 11" tall
HE-112: 6 1/2" diameter, 12 3/4" tall
HE-113: 7 1/4" diameter, 13 1/3" tall
HE-114: 8" diameter, 14 1/2" tall
MATERIALS Aluminum shell; Synthetic head
FEATURE Hand hammered shell
INCLUDES Tuning key

7 ALUMINUM DARBUKAS, PLAIN

SIZES **HE-100:** 5 1/3" diameter, 9 1/4" tall
HE-101: 5 7/8" diameter, 11" tall
HE-102: 6 1/2" diameter, 12 3/4" tall
HE-103: 7 1/4" diameter, 13 1/3" tall
HE-104: 8" diameter, 14 1/2" tall
MATERIALS Aluminum shell; Synthetic head
INCLUDES Tuning key

ARTISAN EDITION, MINI & STANDARD DOUMBEKS



8 3/4", white
HEAD-136

8 3/4", black
HEAD-137

8 3/4", clear
HEAD-138



White Pearl, 8 3/4"
AEED1

White Pearl, 8 3/4"
AEED2

Blue Pearl, 8 3/4"
AEED3

White Pearl, 9"
AEED4

NEW

DARBUKAS & DOUMBEKS



4"
HE-1030

4"
HE-1018



10"
HE-3218

8 1/2"
HE-3018

6"
HE-2018

HAND ENGRAVED SHELL

8 1/2"
HE-3039

PAINTED FLORAL DESIGN



8 1/2"
HE-3012

HAND ENGRAVED SHELL



8 1/2"
HE-3030

HAND HAMMERED SHELL



10"
HE-3200

8 1/2"
HE-3000

6"
HE-2000

LEATHERETTE COVERED SHELL

8 ARTISAN EDITION EGYPT DOUMBEK HEADS

SIZE 8 3/4" diameter
MATERIAL Synthetic head
FEATURES Designed for the MEINL Artisan Edition Doumbeks
COLOURS **HEAD-136:** White
HEAD-137: Black
HEAD-138: Clear

9 ARTISAN EDITION EGYPT DOUMBEKS

SIZES **AEED1, AEED2, AEED3:** 8 3/4" diameter, 17" tall
AEED4: 9" diameter, 18 3/4" tall
MATERIALS Aluminum shell; Synthetic head; Mother of pearl inlays
FEATURES Authentic Egyptian mosaic inlays; Produces outstanding dums and taks (teks)
INCLUDES Tuning key
DESIGNS **AEED1:** Mosaic Royale
AEED2: Mosaic Imperial

AEED3: Mosaic Palace
AEED4: Mosaic Queen

10 MINI DOUMBEKS

SIZE 4" diameter, 7 1/2" tall
MATERIALS Aluminum shell; Synthetic head
FEATURES **HE-1018:** Hand engraved shell
HE-1030: Hand hammered shell
INCLUDES Tuning key

11 ALUMINUM DOUMBEKS, HAND ENGRAVED

SIZES **HE-2018:** 6" diameter, 12" tall (Soprano)
HE-3018, HE-3039: 8 1/2" diameter, 17 1/8" tall
HE-3218: 10" diameter, 18 1/4" tall (Bass)
MATERIALS Aluminum shell; Synthetic head
FEATURES **HE-2018:** High pitched articulate sounds
HE-3039: Painted floral design
HE-3218: Super deep tones
INCLUDES Tuning key

12 COPPER DOUMBEK, HAND ENGRAVED

SIZE 8 1/2" diameter, 17 1/8" tall
MATERIALS Copper shell; Synthetic head
INCLUDES Tuning key

13 ALUMINUM DOUMBEK, HAND HAMMERED

SIZE 8 1/2" diameter, 17 1/8" tall
MATERIALS Aluminum shell; Synthetic head
INCLUDES Tuning key

14 ALUMINUM DOUMBEKS

SIZES **HE-2000:** 6" diameter, 12" tall (Soprano)
HE-3000: 8 1/2" diameter, 17 1/8" tall
HE-3200: 10" diameter, 18 1/4" tall (Bass)
MATERIALS Aluminum shell (leatherette covered); Synthetic head
FEATURES **HE-2000:** High pitched articulate sounds
HE-3200: Super deep tones
INCLUDES Tuning key
COLOUR Black

POP OFF CONGAS

1



11 1/2"
VR-POH115-SH

9 1/2"
VR-POH95-SH

8"
VR-POH8-SH



11 1/2"
VR-POH115-NH

9 1/2"
VR-POH95-NH

8"
VR-POH8-NH

MAY BE PLAYED BY THEMSELVES AS A SMALL HAND DRUM

2

CAN BE TAKEN OFF THE DRUM INSTANTLY WITHOUT ANY TUNING



BOOM SERIES



11 1/2" x 24 1/2"
VR-CPO115-SH

9 1/2" x 23"
VR-CPO95-SH

8" x 21"
VR-CPO8-SH

Set, 3 pcs.
VR-CPOSET-SH

STACKABLE FOR EASY STORAGE AND TRANSPORTATION



SOFT SOUND SERIES



11 1/2" x 24 1/2"
VR-CPO115-NH

9 1/2" x 23"
VR-CPO95-NH

8" x 21"
VR-CPO8-NH

Set, 3 pcs.
VR-CPOSET-NH

1 POP OFF HEADS

SIZES **VR-POH8:** 8" head diameter
VR-POH95: 9 1/2" head diameter
VR-POH115: 11 1/2" head diameter

MATERIALS **SH:** Synthetic head
NH: Napa head

FEATURES Available as Napa style (soft sound) or standard synthetic (sharp sounds)
Instantly take on or off your MEINL VivaRhythm® Pop Off Conga
May be played by themselves as a small hand drum
Nylon-loop for easy removal
Pre-tuned

2 POP OFF CONGAS

SIZES **VR-CPO8**
8" head diameter, 21" height
VR-CPO95
9 1/2" head diameter, 23" height
VR-CPO115
11 1/2" head diameter, 24 1/2" height
VR-CPOSET
8" x 21"; 9 1/2" x 23"; 11 1/2" x 24 1/2"

MATERIALS Synthetic shell
SH: Synthetic head
NH: Napa head

FEATURES Synthetic shell is perfect for outdoor playing
Non-slip rubber bottom
Great for any skill level or style
Stackable for easy storage and transportation
SH: Removable, pre-tuned synthetic head for cutting sounds with sharp attack
NH: Removable, pre-tuned Napa head creates softer, warmer sound

INCLUDES **VR-CPOSET:** Three wooden beaters

POP OFF BASS DRUMS



1

14"
VR-POHBD14-SH

12"
VR-POHBD12-SH

10"
VR-POHBD10-SH

REVERSE-DOT FOR DEEPER SOUNDS

14"
VR-POHBD14-NH

12"
VR-POHBD12-NH

10"
VR-POHBD10-NH

2

CAN BE TAKEN OFF THE DRUM INSTANTLY WITHOUT ANY TUNING

BOOM SERIES

14" x 23 1/2"
VR-BDPO14-SH

12" x 19 1/2"
VR-BDPO12-SH

10" x 18"
VR-BDPO10-SH

Set, 3 pcs.
VR-BDPOSET-SH

STACKABLE FOR EASY STORAGE AND TRANSPORTATION

SOFT SOUND SERIES

14" x 23 1/2"
VR-BDPO14-NH

12" x 19 1/2"
VR-BDPO12-NH

10" x 18"
VR-BDPO10-NH

Set, 3 pcs.
VR-BDPOSET-NH

POP OFF CONGAS & BASS DRUMS

1 POP OFF BASS DRUM HEADS

SIZES **VR-POHBD10:** 10" head diameter
VR-POHBD12: 12" head diameter
VR-POHBD14: 14" head diameter

MATERIALS **SH:** Synthetic head
NH: Napa head

FEATURES Available as Napa style (soft sound) or standard synthetic (sharp sounds)
Instantly take on or off your MEINL VivaRhythm® Pop Off Bass Drum
Reverse Dot below the head for deeper sounds
May be played by themselves as a small hand drum
Nylon-loop for easy removal
Pre-tuned

2 POP OFF BASS DRUMS

SIZES **VR-BDPO10**
10" head diameter, 18" height
VR-BDPO12
12" head diameter, 19 1/2" height
VR-BDPO14
14" head diameter, 23 1/2" height
VR-BDPOSET
10" x 18"; 12" x 19 1/2"; 14" x 23 1/2"

MATERIALS Synthetic shell
SH: Synthetic head
NH: Napa head

FEATURES Synthetic shell is perfect for outdoor playing
Non-slip rubber bottom
Great for any skill level or style
Lower tones with great resonance
Reverse Dot below the head for deeper sounds
Stackable for easy storage and transportation
SH: Removable, pre-tuned synthetic head for cutting sounds with sharp attack
NH: Removable, pre-tuned Napa head creates softer, warmer sound

INCLUDES **VR-BDPOSET:** Three wooden beaters

ALUMINUM SURDOS

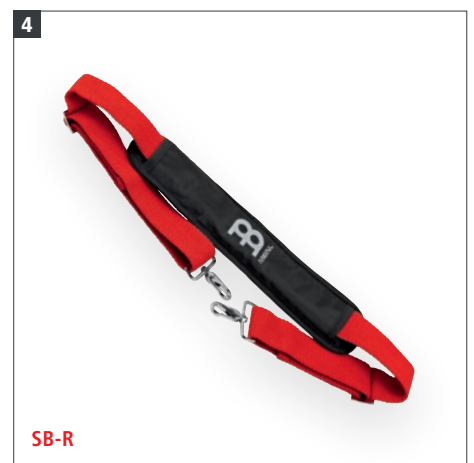

1 CLASSIC SERIES SURDOS (PATENTED)

SIZES **SUC16:** 16" diameter, 20" tall
SUC18: 18" diameter, 22" tall
SUC20: 20" diameter, 24" tall

MATERIAL Aluminum

FEATURES Countersunk bolt heads
Traditional rim
Chrome plated hardware
Traditional plain shell
8 tuning lugs (16" & 18" models)
10 tuning lugs (20" model)
Logo applied from underneath the head
(CN, TH, US patent)

INCLUDES Tuning key

2 BAHIA ALUMINUM SURDOS (PATENTED)

SIZES **SUB18:** 18" diameter, 16" tall
SUB20: 20" diameter, 16" tall
SUB22: 22" diameter, 18" tall

MATERIAL Aluminum

FEATURES Countersunk bolt heads
Chrome plated hardware
Two head options
8 tuning lugs (18" model)
10 tuning lugs (20" & 22" models)
Logo applied from underneath the head
(CN, TH, US patent)

INCLUDES Tuning key

3 TRADITIONAL ALUMINUM SURDOS (PATENTED)

SIZES **SU16:** 16" diameter, 20" tall
SU18: 18" diameter, 22" tall
SU20: 20" diameter, 24" tall
SU22: 22" diameter, 24" tall

MATERIAL Aluminum

FEATURES Countersunk bolt heads
Chrome plated hardware
Two head options
8 tuning lugs (16" & 18" models)
10 tuning lugs (20" & 22" models)
Logo applied from underneath the head
(CN, TH, US patent)
SU22-L, SU20-L, SU18-L, SU16-L:
Height adjustable legs

INCLUDES Tuning key



22" **HEAD-69** 20" **HEAD-68** 18" **HEAD-67** 16" **HEAD-66**



SHORTER SHELLS ENABLE TO WEAR IN MUCH LOWER POSITION

22" **SUB22AB-M** 20" **SUB20AB-M** 18" **SUB18AB-M**



22" **SU22AB-M** 20" **SU20AB-M** 18" **SU18AB-M** 16" **SU16AB-M**

SIX-PLY HARDWOOD SHELLS FOR A FULL AND WARM SOUND

SAMBA BEATERS (SEE PAGE 89)



SB1 **SB4** **SB5**

SURDO BEATER HOLDER (SEE PAGE 89)



SBH



22" **SU22-L-AB-M** 20" **SU20-L-AB-M** 18" **SU18-L-AB-M** 16" **SU16-L-AB-M**

HEIGHT ADJUSTABLE LEGS

4 SAMBA BELT

MATERIAL Cotton
FEATURES Length adjustable
 Adjustable shoulder padding
 Strong attachment hooks
COLOUR **R:** Red

5 SURDO NAPA HEADS

SIZES **HEAD-66:** 16"
HEAD-67: 18"
HEAD-68: 20"
HEAD-69: 22"
MATERIALS Nylon and leather cloth
FEATURE Bonded in a hoop
COLOUR Black

6 BAHIA WOOD SURDOS (PATENTED)

SIZES **SUB18:** 18" diameter, 16" tall
SUB20: 20" diameter, 16" tall
SUB22: 22" diameter, 18" tall
MATERIAL Six-ply hardwood shells
FEATURES Countersunk bolt heads
 Chrome plated hardware
 Two head options
 8 tuning lugs (18" model)
 10 tuning lugs (20" & 22" models)
 Logo applied from underneath the head (CN, TH, US patent)
INCLUDES Tuning key
COLOUR **AB:** Antique Brown
FINISH Matte

7 TRADITIONAL WOOD SURDOS (PATENTED)

SIZES **SU16:** 16" diameter, 20" tall
SU18: 18" diameter, 22" tall
SU20: 20" diameter, 24" tall
SU22: 22" diameter, 24" tall
MATERIAL Six-ply hardwood shells
FEATURES Countersunk bolt heads
 Chrome plated hardware
 Two head options
 8 tuning lugs (16" & 18" models)
 10 tuning lugs (20" & 22" models)
 Logo applied from underneath the head (CN, TH, US patent)
SU22-L, SU20-L, SU18-L, SU16-L:
 Height adjustable legs
INCLUDES Tuning key
COLOUR **AB:** Antique Brown
FINISH Matte

TIMBAS, TANTAM, REBOLO, REPINIQUES & CUICAS



1 TIMBAS (PATENTED)

SIZES **TIM1428:** 14" diameter, 28" tall
TIM1435: 14" diameter, 35" tall

MATERIALS Poplar Wood (*Populus*)
Replaceable synthetic head

FEATURES Lightweight shell; Chrome plated hardware; Comfortable rounded rim; Strong hook to carry it on a belt; Logo applied from underneath the head (CN, TH, US patent)

INCLUDES Tuning key

COLOUR **AB-M:** Antique Brown, matte

2 TANTAM

SIZE 14" diameter, 28" tall

MATERIALS Poplar Wood (*Populus*)
Replaceable synthetic Napa head

FEATURES Lightweight shell; Chrome plated hardware; Strong hooks to carry it on a belt

INCLUDES Tuning key

COLOUR **AB-M:** Antique Brown, matte

3 REBOLO

SIZE 12" diameter, 18" tall

MATERIALS Poplar Wood (*Populus*)
Replaceable synthetic Napa head

FEATURES Lightweight shell; Chrome plated hardware; Mechanical lug tuning; Strong hooks to carry it on a belt

INCLUDES Tuning key

COLOUR **AB-M:** Antique Brown, matte

4 ALUMINUM REPINIQUES (PATENTED)

SIZES **RE10:** 10" diameter, 10" tall
RE12: 12" diameter, 12" tall

MATERIALS Aluminum
Replaceable synthetic heads

FEATURES Countersunk bolt heads; Chrome plated hardware; 6 tuning lugs (10" model); 8 tuning lugs (12" model); Logo applied from underneath the head (CN, TH, US patent)

INCLUDES Tuning key

5 ALUMINUM CUICAS

SIZES **QW6:** 6" diameter
QW10: 10" diameter

MATERIALS Aluminum
Hand selected goatskin heads

FEATURE **QW10:** Countersunk bolt heads

INCLUDES Tuning key

CAIXAS & TAMBORIMS



SAMBA

6



14" x 4"
CA14

PROFESSIONAL SNARE
THROW-OFF MECHANISM



12" x 4 1/2"
CA12

7

TRADITIONAL STYLE
WITH GUITAR STRINGS



12" x 6"
CA12T

IMPROVED

8

MESH HEAD FOR SUPER LOW VOLUME
PRACTICE



ABS, Black
STBR06ABS-BK

9



ABS, Black
TBR06ABS-BK



ABS, Green
TBR06ABS-GR

TAMBORIM STICKS
(SEE PAGE 88)



TBR5-BK TBR5-R



ABS, Red
TBR06ABS-R



ABS, Yellow
TBR06ABS-Y

PROFESSIONAL TAMBORIM
BAG (SEE PAGE 103)



MTAB-06



Aluminum
TBR06ALU



6 ALUMINUM CAIXAS (PATENTED)

SIZES CA12: 12" diameter, 4 1/2" tall
CA14: 14" diameter, 4" tall

MATERIALS Aluminum; Replaceable synthetic heads
FEATURES Countersunk bolt heads; Steel snare wires; Professional snare throw-off mechanism; Logo applied from underneath the head (CN, TH, US patent)
INCLUDES Tuning key

7 TRADITIONAL ALUMINUM CAIXA (PATENTED)

SIZE 12" diameter, 6" tall
MATERIALS Aluminum; Replaceable synthetic heads
FEATURES Traditional style snares made from guitar strings; Extra deep body; Countersunk bolt heads; Logo applied from underneath the head (CN, TH, US patent)
INCLUDES Tuning key

8 SILENT TAMBORIM

SIZE 6" diameter
MATERIALS Molded ABS
REPLACEABLE MESH HEAD
FEATURE Floatune Tuning System; Countersunk bolt lugs; Mesh head for super low volume practice
INCLUDES Washer as tuning key
COLOUR BK: Black

9 FLOATUNE TAMBORIMS (PATENTED)

SIZE 6" diameter
MATERIALS Replaceable synthetic heads
ABS: ABS
ALU: Aluminum
FEATURES Floatune Tuning System; Countersunk bolt lugs; Logo applied from underneath the head (CN, TH, US patent)
INCLUDES Washer as tuning key
COLOURS BK: Black
GR: Green
R: Red
Y: Yellow

FRAME DRUMS



<p>1 HAND DRUMS</p> <p>SIZES HD10: 10"; HD12: 12"; HD14: 14"; HD16: 16"; HD18: 18"; HD20: 20"; HD22: 22"</p> <p>MATERIALS Siam Oak (<i>Hevea brasiliensis</i> Muell.-Arg.) AB: Hand selected goatskin head AB-TF: True Feel synthetic head</p> <p>COLOUR Antique Brown</p> <p>2 TARS</p> <p>SIZES FD16: 16", 2 1/2" deep FD18: 18", 2 1/2" deep FD20: 20", 2 1/2" deep FD22: 22", 2 1/2" deep</p> <p>MATERIALS Siam Oak (<i>Hevea brasiliensis</i> Muell.-Arg.) T: Hand selected goatskin head T-TF: True Feel synthetic head</p> <p>FEATURE Internal tuning system</p> <p>INCLUDES Hex key</p> <p>COLOUR Antique Brown, matte</p>	<p>3 ARTISAN EDITION TARS (PATENTED)</p> <p>SIZES AE-FD14: 14", 2 1/2" deep AE-FD18: 18", 2 1/2" deep AE-FD22: 22", 2 1/2" deep</p> <p>MATERIALS Siam Oak (<i>Hevea brasiliensis</i> Muell.-Arg.) Hand selected goatskin head</p> <p>FEATURES Special designed bearing edge (DE, US patent); Internal tuning system</p> <p>INCLUDES Hex key</p> <p>COLOUR Walnut Brown, matte</p> <p>4 SEA DRUMS</p> <p>SIZES FD16: 16", 2 3/4" deep FD18: 18", 2 3/4" deep FD20: 20", 2 3/4" deep FD22: 22", 2 3/4" deep</p> <p>MATERIALS Siam Oak (<i>Hevea brasiliensis</i> Muell.-Arg.) Transparent synthetic head and SD: Hand selected goatskin head SD-TF: True Feel synthetic head</p>	<p>FEATURES Steel balls inside; Sealable filling port</p> <p>COLOUR Antique Brown, matte</p> <p>5 MIZHARS</p> <p>SIZES FD12: 12", 4" deep; FD14: 14", 4" deep; FD18: 18", 4" deep</p> <p>MATERIALS Siam Oak (<i>Hevea brasiliensis</i> Muell.-Arg.) T-D: Hand selected goatskin head T-D-TF: True Feel synthetic head</p> <p>FEATURES Deep shell construction for full sound development; Internal tuning system</p> <p>INCLUDES Hex key</p> <p>COLOUR Brown Burl, matte</p> <p>6 ARTISAN EDITION MIZHARS (PATENTED)</p> <p>SIZES AE-FD14: 14", 4" deep AE-FD18: 18", 4" deep AE-FD22: 22", 4" deep</p> <p>MATERIALS Siam Oak (<i>Hevea brasiliensis</i> Muell.-Arg.) Hand selected goatskin head</p>
-----------------------------------------------------------------------------------------------------------------------------------------------------------------------------------------------------------------------------------------------------------------------------------------------------------------------------------------------------------------------------------------------------------------------------------------------------------------------------------------------------------------------------------------------------------------------------------------------------------------------------------------------------------------------------------------------------------------------------------------------------------------------------------------------------------------------------------------------	--------------------------------------------------------------------------------------------------------------------------------------------------------------------------------------------------------------------------------------------------------------------------------------------------------------------------------------------------------------------------------------------------------------------------------------------------------------------------------------------------------------------------------------------------------------------------------------------------------------------------------------------------------------------------------------------------------------------------------------------------------------------------------------------------------------------------------------------------	----------------------------------------------------------------------------------------------------------------------------------------------------------------------------------------------------------------------------------------------------------------------------------------------------------------------------------------------------------------------------------------------------------------------------------------------------------------------------------------------------------------------------------------------------------------------------------------------------------------------------------------------------------------------------------------------------------------------------------------------------------------------------------------------------------------------------------------------------------------



FEATURES Special designed bearing edge (DE, US patent); Internal tuning system
INCLUDES Hex key
COLOUR Walnut Brown, matte

7 BENDIRS

SIZES **FD12:** 12", 4" deep; **FD14:** 14", 4" deep; **FD16:** 16", 2 1/2" deep
MATERIALS Siam Oak (*Hevea brasiliensis* Muell.-Arg.)
BE: Hand selected goatskin head
BE-TF: True Feel synthetic head
FEATURES Internal tuning system; Buzzing effect
INCLUDES Hex key
COLOUR Antique Brown, matte

8 DAFS

SIZE 20", 2 1/2" deep
MATERIALS Siam Oak (*Hevea brasiliensis* Muell.-Arg.)
FD20D-TF: True Feel synthetic head
FD20D-WH: Woven synthetic head

FEATURE Metal rings for special effects
COLOUR Antique Brown, matte

BODHRANS 9 10

MATERIALS Siam Oak (*Hevea brasiliensis* Muell.-Arg.)
INCLUDES Hand selected goatskin head
INCLUDES Hex key

9 CELTIC BODHRAN

SIZE 18", 4" deep
FEATURES Cross bar; Internal tuning system
COLOUR Antique Brown, matte

10 IRISH BODHRAN

SIZE 14", 6" deep
FEATURES Extra deep shell for full sound development; Dampening layer around rim for reduced overtones
COLOUR Brown Burl, matte

11 KANJIRA

SIZE 7 1/2", 2 1/4" deep
MATERIALS Siam Oak (*Hevea brasiliensis* Muell.-Arg.)
FEATURES Hand selected goatskin head
INCLUDES Many sound options; Set of 3 jingles
COLOUR Antique Brown, matte

12 NATIVE AMERICAN-STYLE HOOP DRUMS

SIZES **HOD125:** 12 1/2"; **HOD15:** 15"
MATERIALS Hand selected buffalo head
FEATURE Nylon lacing and grip
INCLUDES Warm and powerful sound
INCLUDES Leather padded wooden beater

13 PLENERA SET

SIZES 8" Quinto; 10" Seguidor; 12" Tumbador
MATERIALS ABS molded frames; Goatskin heads
FEATURE External mechanical lug tuning
INCLUDES Nylon Bag; Tuning Key

RITUAL DRUMS

1



8 1/2" Bayan & 5 1/2" Dayan
TABLA

2

MADE BY MASTER CRAFTSMEN IN INDIA



9" Bayan & 5 1/2" Dayan
PRO-TABLA



3



ID10WH

4



ID3GO

RAWHIDE PLAYING SURFACE

5



ID9BK/WH

THE FIBERGLASS LIQUID IBO DRUM IS FILLED WITH WATER

PROFESSIONAL DOUMBЕК/IBO STAND (SEE PAGE 93)



TMID

5



ID4BKO

EXTRA FIBERGLASS PLAYING SURFACE

1 TABLA SET

- SIZES** 5 1/2" Dayan
8 1/2" Bayan
- MATERIALS** Chrome plated copper with goatskin head
Mahogany with goatskin head
- FEATURES** Authentic tabla heads
Nylon straps for longer durability
- INCLUDES** Padded support rings; Tuning hammer

2 ARTISAN EDITION TABLA SET

- SIZES** 5 1/2" Dayan
9" Bayan
- MATERIALS** Copper with goatskin head
Mahogany with goatskin head
- FEATURES** Top quality goatskin tabla heads
Traditional tuning system with rawhide thongs
- INCLUDES** Tuning hammer and wooden tuning dowel; Ring pads; Protective head covers

3 QUINTO IBO DRUM

- SIZE** Small
- MATERIAL** Ceramic
- FEATURES** Full and rich sounds
Built-in microphone hole
- COLOUR** **WH:** White

4 FIBERGLASS TRI SOUND IBO DRUMS

- SIZE** Large
- MATERIAL** Premium fiberglass
- FEATURES** Built-in microphone hole
Resistant shell construction
ID3GO: Rawhide playing surface
ID4BKO: Extra fiberglass playing surface
- INCLUDES** Foam padded base
- COLOUR** **BKO:** Black Ornament
GO: Gold Ornament

5 FIBERGLASS LIQUID IBO DRUM

- SIZE** Large
- MATERIAL** Premium fiberglass
- FEATURES** Special bottom, filled with water
Built-in microphone hole
Resistant shell construction
- INCLUDES** Foam padded base
- COLOUR** **BK/WH:** Black/White

6 BATAS

- SIZES** **BA1:** 5 1/4" & 8" Okonkolo
BA2: 5 3/4" & 8 3/4" Itotele
BA3: 6 3/4" & 12" Iya
- MATERIALS** Premium fiberglass
Hand selected buffalo heads
- FEATURE** Traditional TTR-Rims
- INCLUDES** Nylon strap; Tuning key
- COLOUR** **BK:** Black



6 3/4" & 12" Iya **BA3BK** 5 3/4" & 8 3/4" Itotele **BA2BK** 5 1/4" & 8" Okonkolo **BA1BK**



8" x 16" **ATD-L** 7" x 12" **ATD-M**

COMES WITH A CURVED WOODEN BEATER



11" **MTA1SNT-M**

TRUE SKIN BUFFALO HEADS



BE1R



8" & 9" **HCG89NT**

HEAVY-DUTY STAND CAN BE TILTED



SH-R **SHR-BR** **SHK**

NEW

NEARLY UNBREAKABLE

7 AFRICAN WOOD TALKING DRUMS

SIZES **M:** 7" diameter, 12" tall
L: 8" diameter, 16" tall
PP ROPES **M:** 3 mm thickness, 23 runners
L: 3 mm thickness, 28 runners
MATERIALS Mahogany Wood (*Swietenia macrophylla*)
Hand selected goatskin heads
FEATURE Nylon tuning strap
INCLUDES Curved wooden beater
FINISH Brown/Black

8 TAMBORA

SIZE 11"
MATERIALS Siam Oak (*Hevea brasiliensis* Muell.-Arg.)
True Skin Buffalo Heads
FEATURE Black powder coated hardware
INCLUDES Nylon strap; Wooden beaters; Tuning key
COLOUR **SNT-M:** Super Natural
FINISH Matte

9 BERIMBAU

MATERIAL Premium fiberglass
INCLUDES Small Caxixi; Metal plate; Wooden stick;
Carrying bag
COLOUR **R:** Red

10 WOOD CONGUITAS

SIZES 8" & 9"
MATERIALS Siam Oak (*Hevea brasiliensis* Muell.-Arg.)
Hand selected buffalo heads
FEATURES 8 mm strong tuning lugs; Original MEINL style tuning brackets; Traditional rims; Black powder coated hardware
INCLUDES Height adjustable tilting double braced tripod stand; Tuning key; Wrench
COLOUR **NT:** Natural
FINISH High gloss

11 SHEKERES

SIZES **SH-R, SHR-BR:** Medium
SHK: Traditional
MATERIALS **SH-R, SHR-BR:** Premium fiberglass
SHK: Gourd
COLOURS **BR:** Brown
R: Red

STICKS, BEATERS, BRUSHES, MALLETS & SCRAPERS



Bass Beat Cajon Brush
CB4

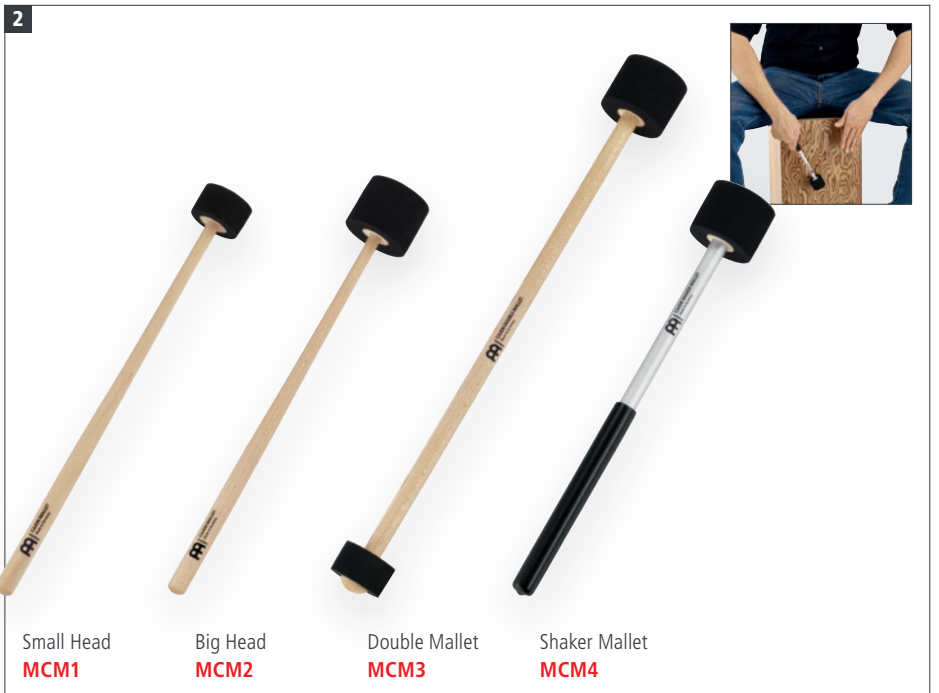

Small Head **MCM1** Big Head **MCM2** Double Mallet **MCM3** Shaker Mallet **MCM4**



Black **TBRS-BK** Red **TBRS-R**



FDT1
FDT2
FDT3
FDT4
FDT5



Long **SST1-L** Medium **SST1-R** Short **SST1-S** Triple **SST3** Triple short **SST3-S**



NEW

Soft **MPMS**
Medium **MPMM**
Hard **MPMH**

1 BASS BEAT CAJON BRUSH

SIZE 13" long
MATERIALS Polymer bristles
Foam rubber
FEATURES Straight polymer bristles for ultra-smooth precision; Soft foam rubber for full-bodied low notes; Two adjustable control rings; Flexible handle

2 CAJON MALLET COLLECTION

SIZES **MCM1, MCM4:** 11 3/4" long
MCM2: 12 1/4" long
MCM3: 15 1/2" long
MATERIALS Foam rubber
MCM1, MCM2, MCM3: Hard maple
MCM4: Aluminum
FEATURES Made in Germany
MCM1: Made out of the finest hand-selected maple; Small foam rubber head; Designed for softer playing
MCM2: Made out of the finest hand-selected maple; Extra thick foam rubber head
MCM3: Made out of the finest hand-selected maple; Foam rubber padding; Two different ends for contrasting sounds
MCM4: Integrated shaker effect in handle; Soft foam rubber head; Lightweight aluminum handle

3 TAMBORIM STICKS

MATERIAL Synthetic
COLOURS **BK:** Black
R: Red

4 BODHRAN TIPPERS

MATERIAL Ash Wood
COLOUR Antique Brown

5 SAMBA STICKS

SIZES **SST1-S:** Stick, short version
SST1-R: Stick, medium version
SST1-L: Stick, long version
SST3-S: Triple stick, short version
SST3: Triple stick
MATERIAL Synthetic

7

Big felt head, medium hard
MPM1

Small felt head, hard
MPM2

Small rubber head, hard
MPM3

Small rubber head, soft
MPM4

8

American Hickory
MPM5

9 EASY MOUNTABLE

HAM1BK

10

Siam Oak
COW1

Molded ABS
COW3BK

Siam Oak
COW1BK

Siam Oak
COW2

PADDED BEATER SECTION

11

2" felt beater
SB1

2" felt beater
SB2

2 1/2" felt beater
SB3

2" leather beater
SB4

3" bushy felt beater
SB5

12

SBH

13

Mahogany Wood
SPARE-23

14

Wood
MGS1

ABS
MGS2

6 MOLDED ABS PERCUSSION MALLETS
 SIZE 12 1/4" long
 MATERIAL Durable molded ABS
 FEATURES Easy to play across many different percussion instrument types
MPMS: Soft
MPMM: Medium
MPMH: Hard

7 PERCUSSION MALLETS
 SIZE 12 1/2" long
 MATERIALS Hard maple
MPM1: Big felt head, medium hard
MPM2: Small felt head, hard
MPM3: Small rubber head, hard
MPM4: Small rubber head, soft
 FEATURES Made out of the finest hand-selected maple; Great for woodblocks and synthetic percussion blocks; Made in Germany

8 TEMPLE & WOOD BLOCK MALLETS
 SIZE 12 1/2" long
 MATERIAL American Hickory
 FEATURES Soft rubber mallet heads for wood blocks; Solid hickory handles

9 HANDMATE
 MATERIAL Steel construction with a wooden ball
 FEATURE Fully adjustable

10 COWBELL BEATERS
 MATERIALS **COW1, COW2:** Siam Oak (*Hevea brasiliensis* Muell.-Arg.)
COW3: Molded ABS
 FEATURES Ribbed grip; Durable construction

11 SAMBA BEATERS
 SIZES **SB1:** 15" long
SB2, SB3, SB4, SB5: 16" long
 MATERIALS **SB1:** Aluminum stick with 2" felt beater
SB2: Wood stick with 2" felt beater
SB3: Wood stick with 2 1/2" felt beater
SB4: Wood stick with 2" leather beater
SB5: Wood stick with 3" bushy felt beater

12 SURDO BEATER HOLDER
 MATERIAL Leather
 COLOUR Black

13 TALKING DRUM BEATER
 MATERIAL Mahogany Wood

14 GÜIRA SCRAPERS
 MATERIALS Steel rods
MGS1: Ergonomic wooden grip
MGS2: Sanded ABS grip

STANDS

1



Black powder coated

Black powder coated

For Marathon® Classic Series
For Marathon® Designer Series
For Luis Conte Artist Series
ST-MCC11BK: 11"
ST-MCC1134BK: 11 3/4"
ST-MCC1212BK: 12 1/2"



Chrome plated

Chrome plated

For Marathon® Exclusive Series
ST-MEC11CH: 11"
ST-MEC1134CH: 11 3/4"
ST-MEC1212CH: 12 1/2"
For Professional Series
For Fibercraft Series
ST-MP11CH: 11"
ST-MP1134CH: 11 3/4"
ST-MP1212CH: 12 1/2"
For Floatune Series
ST-FL10CH: 10"
ST-FL11CH: 11"
ST-FL12CH: 12"
ST-FL13CH: 13"
For Woodcraft Series
ST-WC11CH: 11"
ST-WC1134CH: 11 3/4"
ST-WC1212CH: 12 1/2"

Gold tone

Gold tone

For Marathon® Exclusive Series
ST-MEC11G: 11"
ST-MEC1134G: 11 3/4"
ST-MEC1212G: 12 1/2"
For Mongo Santamaria Artist Series
ST-MSA11G: 11"
ST-MSA1134G: 11 3/4"
ST-MSA1212G: 12 1/2"

QUICK AND EASY HEIGHT ADJUSTABILITY (DE PATENT)

2

EASY HEIGHT EXTENSION

Black powder coated
ST-HEBK

Chrome plated
ST-HECH

Gold tone
ST-HEG



3



MIN. 43"
MAX. 52 3/4"

For Headliner® congas
HDSTAND

For MCC congas
TMDS

4



For HDSTAND and TMDS
THBM

EASY MOUNTABLE

6



Chrome plated
MCH-CH

Gold tone
MCH-G

FOR ANY CONGA

5



Chrome plated
TMPDS

1 STEELY II CONGA STANDS (PATENTED)

MATERIAL Steel
FEATURES Metal spike attachment on each leg
L-shaped legs (DE, TH, US patent)
U-shaped notch for quick set up and breakdown (US patent)
Ergonomic arched rubber bracing for more stability (CN, DE, TH, US patent)
Notches for quick height adjustability (DE patent)
INCLUDES Hex key

2 STEELY II CONGA STAND HEIGHT EXPANDER SETS (DE PATENT)

MATERIAL Steel
FEATURE Easy and effective height extension
INCLUDES Mounting screws; Hex key
FINISHES **BK:** Black powder coated
CH: Chrome plated
G: Gold tone

3 CONGA DOUBLE STANDS

MATERIAL Steel
FEATURES Height adjustable
Double braced tripod legs
INCLUDES Hex key; Memory locks; Brackets; Set of screws, nuts, and washers; Mounting instructions

4 BONGO MOUNT

MATERIAL Chrome plated steel
FEATURES Easy mountable on our conga double stands HDSTAND and TMDS
Holds your bongo in place
Adjustable angle

5 PROFESSIONAL CONGA DOUBLE STAND WITH WHEELS

MATERIAL Chrome plated steel

FEATURES Height adjustable
Heavy construction
Double braced tripod legs
Lockable high-quality wheels
Padded separators for adjustable angle
Mounting instructions
INCLUDES Two mounting brackets

6 CONGA HANDLES

MATERIAL Steel
FEATURES Simple and safe add-on to help transport congas
Easily mountable with instructional guide
Fits any common conga
Leaves sound unaffected
INCLUDES Mounting screws and washers; Mounting instructions
FINISHES **CH:** Chrome plated
G: Gold tone

7 **STURDY LOCKABLE WHEELS MAKE IT EASY TO MOVE THE STAND INTO POSITION**

Chrome plated
TMPC

8 **THE LIGHTWEIGHT STAND CAN BE FOLDED TO A COMPACT UNIT WHICH REQUIRES LITTLE SPACE**

Chrome plated
TMC-CH

COMPATIBLE FOR ALL SIZES!

9

MIN. 34 1/2"
MAX. 50"

Black powder coated
THBS-BK

Chrome plated
THBS

AN INNOVATIVE BRACKET DESIGN ENABLES QUICK SET UP (PATENTED)

10 **PADDED T-SHAPED TUBE FOR MORE STABILITY**

MIN. 31 1/2"
MAX. 52 3/4"

Chrome plated
TMB

11 **A STABLE METAL CLAMP HOLDS THE ENTIRE UNIT IN PLACE**

MIN. 12 1/4"
MAX. 20"

Chrome plated
TMB-S

LOW HEIGHT FOR SEATED PLAYERS

12 **PERFECT HEIGHT FOR CAJON PLAYERS**

MIN. 22 3/4"
MAX. 29 1/2"

Black powder coated
THBS-S-BK

13 **DIFFERENT RODS FOR ALL NEEDS**

MIN. 31 1/2"
MAX. 52 1/2"

Chrome plated
TMPS

7 PROFESSIONAL CONGA STAND WITH WHEELS

- MATERIAL** Chrome plated steel
- FEATURES** Adjustable padded stops fit any conga size
Height adjustable legs
Lockable wheels

- FEATURES** Quick set up
Easy handling
Reliable placement
Double braced tripod stand
Fits all common bongos
- INCLUDES** Wrench
- FINISHES** **THBS:** Chrome plated
THBS-BK: Black powder coated

- FEATURES** Seated playing position possible
Padded T-shaped tube
Fully height and angle adjustable
Double braced tripod legs
Fits all common bongos
- INCLUDES** Hex key; Memory lock

8 PROFESSIONAL CONGA STAND

- MATERIAL** Chrome plated steel
- FEATURES** Unique design (DE patent)
Rubber padded crossbeams
Fully height adjustable
Folds up to a compact unit
- INCLUDES** Hex key; Memory locks

10 PROFESSIONAL BONGO STAND

- MATERIAL** Chrome plated steel
- FEATURES** Padded T-shaped tube
Fully height and angle adjustable
Double braced tripod legs
Fits all common bongos
- INCLUDES** Hex key; Memory locks

12 CAJON HEIGHT BONGO STAND

- MATERIAL** Black powder coated steel
- FEATURES** Quick set up
Easy handling
Perfect height for cajon players
Fits all common bongos

9 HEADLINER® SERIES BONGO STANDS (CN, DE, US PATENT)

- MATERIAL** Steel









11 PROFESSIONAL BONGO STAND FOR SEATED PLAYERS

- MATERIAL** Chrome plated steel

13 PERCUSSION STAND

- MATERIAL** Chrome plated steel
- FEATURES** Height adjustable
Double braced tripod legs
- INCLUDES** Hex key; Memory locks; 2 straight rods;
2 angled rods; 2 Z-shaped rods

STANDS

<p>1 COLLAPSIBLE DESIGN</p>  <p>Black powder coated STDJST-BK</p>	<p>2</p>  <p>QUICK AND EASY HEIGHT ADJUSTABILITY (DE PATENT)</p>  <p>Chrome plated ST-DJEMBE</p>	<p>3 LENGTH ADJUSTABLE FOR VARIOUS DJEMBE SIZES</p>   <p>MIN. 23 1/2" MAX. 37 3/4"</p> <p>Chrome plated TMD</p>	<p>4 FITS ALL CAJON SIZES</p>  <p>MIN. 26" MAX. 40 1/2"</p> <p>Black powder coated TMCAJ</p>
<p>5</p>  <p>CMS</p>	<p>CAJON DRUM SET STANDS (SEE PAGE 47)</p>  <p>CHS CCS CAS</p>	<p>6</p>  <p>MIN. 22" MAX. 37"</p> <p>Black powder coated CPTS</p>	<p>7 SPECIAL LOW HEIGHT</p>  <p>MIN. 29 1/2" MAX. 38"</p> <p>Chrome plated MLH</p>

1 TRAVEL DJEMBE STAND

MATERIAL Black powder coated steel
FEATURES Collapsible design
Lightweight construction

2 STEELY II DJEMBE STAND (PATENTED)

MATERIAL Chrome plated steel
FEATURES Metal spike attached to each leg
L-shaped legs (DE, TH, US patent)
U-shaped notch for quick set up and breakdown (US patent)
Ergonomic arched rubber bracing for more stability (CN, DE, US patent)
Notches for quick height adjustability (DE patent)
Adapts to different djembe sizes
INCLUDES Hex key, 3 spacers

3 PROFESSIONAL DJEMBE STAND

MATERIAL Chrome plated steel
FEATURES Rubber padded hooks
Fully height and angle adjustable
Double braced tripod legs
INCLUDES Hex key; Memory lock

4 PROFESSIONAL CAJON STAND

MATERIAL Steel
FEATURES Quick set up
Fully height and angle adjustable
Double braced tripod stand
Fits all cajon sizes

5 CAJON MICROPHONE STAND

MATERIAL Black powder coated aluminum
FEATURES Round base for compact setup
Solid construction
Height adjustable

6 CAJON PICKUP TAPS STAND

MATERIAL Black powder coated aluminum
FEATURES Designed to mount the MEINL Cajon Pickup Tom and Snare Taps
Low-key stage footprint
L-Shaped 3/8" rod
Foldable legs, height adjustable

7 LOW HAT

MATERIAL Chrome plated steel
FEATURES Special low height
Made just for cajon players

8 TIMBALE STAND

MATERIAL Chrome plated steel
FEATURES Double braced tripod base
Height and angle adjustable
Standard mounting rod for auxiliary percussion

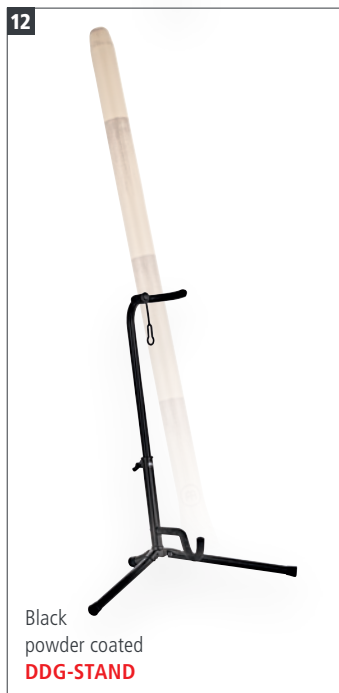

INCLUDES Accessory pouch; L-shaped tuning key; Tune Up Oil

9 PROFESSIONAL TIMBALE STAND

MATERIAL Chrome plated steel

FEATURES Heavy-duty double braced tripod base
Height and angle adjustable
Standard mounting rod for auxiliary percussion

INCLUDES Accessory pouch; Tuning key; Tune Up Oil

10 HAND-BALE STAND

MATERIAL Chrome plated steel

FEATURES Quick set up
Rubber-tipped three arm basket
Easy handling
Double braced tripod stand

11 PROFESSIONAL DOUMBЕК/IBO STAND

MATERIAL Chrome plated steel

FEATURES Foam padded ring
Fully height and angle adjustable
Double braced tripod legs

INCLUDES Hex key; Memory lock

12 DIDGERIDOO STAND

MATERIAL Black powder coated aluminum

FEATURES Steady support for your didgeridoo
Stable tripod base
Soft padding
Rubber yoke for added protection

FINISH Black

13 PROFESSIONAL DIDGERIDOO STAND

MATERIAL Black powder coated aluminum

FEATURES Dual leg base and strong aluminum construction
Protective rubber yoke and soft padding
Height and angle adjustable

FINISH Black

14 PRO DIDGERIDOO STAND

MATERIAL Chrome plated steel

FEATURES Play your didgeridoo in a seated or standing position
Accommodates most didgeridoo sizes and shapes
Padded rest with adjustable strap

15 CHIMES STAND

MATERIAL Chrome plated steel

FEATURES Full angle and height adjustability
Secure angle clamps
Telescoping stem

TABLES

1



MIN. 30"
MAX. 46 3/4"

20" x 12 1/2"
TMLTS

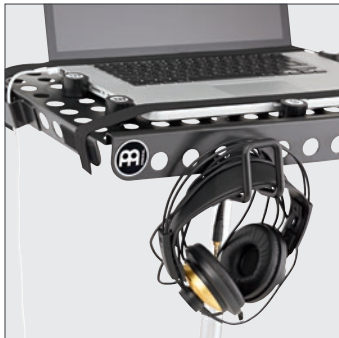

2

FABRIC ANTI-SLIP SURFACE



11" x 7"
MC-PTXS

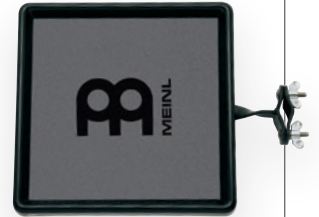

12" x 12"
MC-PTS



18" x 12"
MC-PT



1 LAPTOP TABLE STAND

SIZE 20" x 12 1/2"
MATERIAL Perforated metal plate
FEATURES Holds laptops up to 17"
Stoppers, hook and loop fastener to secure the laptop
Holder for headphones
Cord strain relief

2 PERCUSSION TABLES

SIZES **MC-PT:** 18" x 12"
MC-PTS: 12" x 12"
MC-PTXS: 11" x 7"
MATERIALS **MC-PT, MC-PTS:** Premium fiberglass
MC-PTXS: Synthetic
FEATURES Fabric anti-slip surface
Adjustable angle
Strong mounting clamp

3 HEIGHT ADJUSTABILITY AT ALL POINTS

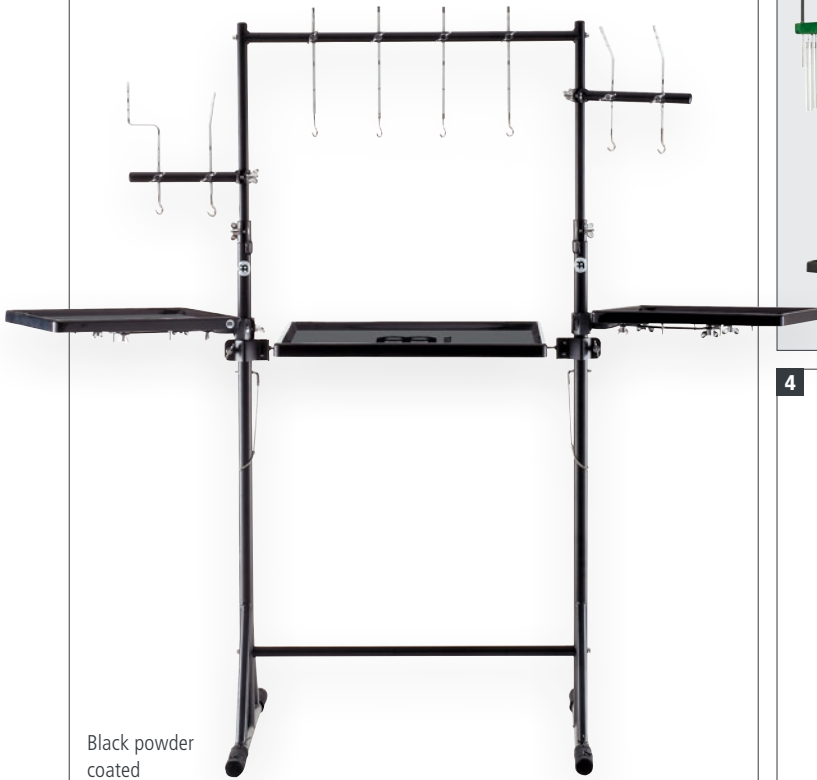

Black powder coated
TMPWS



4 ALL MEINL TRIPOD STANDS ARE EQUIPPED WITH MEMORY AND QUICK LOCKS



MIN. 30"
MAX. 46 3/4"

16" x 22"
TMPTS



3 PERCUSSION WORKSTATION

- MATERIAL** Black powder coated steel
- FEATURES** Fully height adjustable
Angle adjustable top bar
Heavy-duty construction
Infinitely expandable
Fabric anti-slip surfaces
Colour doesn't interfere with stage lighting
- INCLUDES** 1 x Padded fiberglass percussion table, 22" x 24"
2 x Padded fiberglass percussion tables, 18" x 12" (attachable)
1 x Vertical bar, 30"
2 x Vertical bars, 15" (attachable)
4 x Straight rods with hook
3 x Angled rods with hook
1 x Z-shaped rod with hook

4 PERCUSSION TABLE STAND

- SIZE** 16" x 22"
- MATERIALS** Table: Premium fiberglass
Stand: Chrome plated steel
- FEATURES** Fabric anti-slip surface
Fully height adjustable
Double braced tripod legs
- INCLUDES** Hex key
Memory lock

HARDWARE

<p>1 HOLDS TAMBOURINES AND SHAKERS</p>  <p>Mini Percussion Rack MC-SHTA</p>	<p>2 PADED SURFACE</p>  <p>Tambourine Holder MC-TH</p>	<p>3</p> <p>MIN. 1" MAX. 6"</p>  <p>Shaker Holder MC-SH</p>	
<p>4</p> <p>MIN. 2 1/2" MAX. 3 3/4"</p>  <p>Güiro Holder MC-GU</p>	<p>5</p>  <p>Wood Block Holder MWBH1</p>	<p>6</p>  <p>Standard Frame Drum Holder MC-STFDH</p>	<p>7</p>  <p>Triangle Holder MC-TRI</p>
<p>8</p>  <p>Triangle Clamp CLAMP-TRI</p>	<p>9 FOR TURBO CABASA, MEDIUM</p>  <p>Cabasa Holder MC-CA</p>	<p>10</p>  <p>Frame Drum Holder MC-FDH</p>	
<p>11</p>  <p>Chimes Holders MC-CH MC-CHL</p>	<p>12</p>  <p>Drumstick Holders MC-DSH MC-DSH-JB</p>	<p>13</p>  <p>Bass Drum Cowbell Holders MC-STBD MC-BD</p>	

1 MINI PERCUSSION RACK

MATERIALS Black powder coated steel; Foam rubber
FEATURE Holds tambourines and shakers
COLOUR Black

2 TAMBOURINE HOLDER

MATERIAL Chrome plated steel
FEATURES Rubber pads; Padded surface

3 SHAKER HOLDER

MATERIAL Chrome plated steel
FEATURES Rubber pads; Length adjustable

4 GÜIRO HOLDER

MATERIAL Chrome plated steel
FEATURE Rubber pads

5 WOOD BLOCK HOLDER

MATERIAL Chrome plated steel

6 STANDARD FRAME DRUM HOLDER

MATERIAL Chrome plated steel
FEATURE Perfect for frame drums or traditional wood tambourines

7 TRIANGLE HOLDER

MATERIAL Chrome plated steel
FEATURES Knurled surface; Nylon cord

8 TRIANGLE CLAMP

MATERIAL Chrome plated steel
FEATURES Holds any triangle in place; Easy mountable

9 CABASA HOLDER

MATERIAL Chrome plated steel
FEATURES Strong mounting clamp; Padded surface

10 FRAME DRUM HOLDER

MATERIALS Chrome plated steel; Anodized aluminum
FEATURE Fully adjustable for any frame drum size

11 CHIMES HOLDERS

SIZES **MC-CH**: Regular
MC-CHL: Large
MATERIAL Chrome plated steel
FEATURES Knurled surface; Foam washer

12 DRUMSTICK HOLDERS

MATERIALS Chrome plated steel; Black textile pouch
FEATURE Strong mounting clamp
FINISHES **MC-DSH**: MEINL
MC-DSH-JB: Jawbreaker motif

13 BASS DRUM COWBELL HOLDERS

MATERIALS **MC-BD**: Chrome plated steel
MC-STBD: Black powder coated steel
FEATURES Rubber pads
MC-BD: Fully adjustable
INCLUDES **MC-BD**: L-shaped rod



Multi Clamp for Cymbal Stands
PMC-1



Pedal Mount
PM-1



Pedal Mount for Cymbals
PM-2

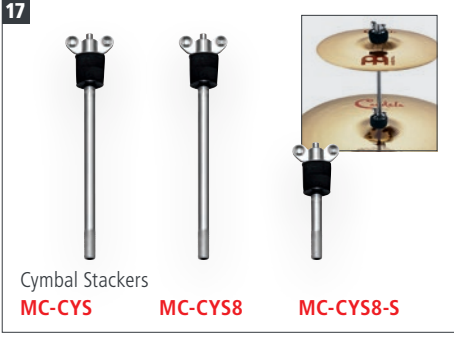

Cymbal Stackers
MC-CYS **MC-CYS8** **MC-CYS8-S**

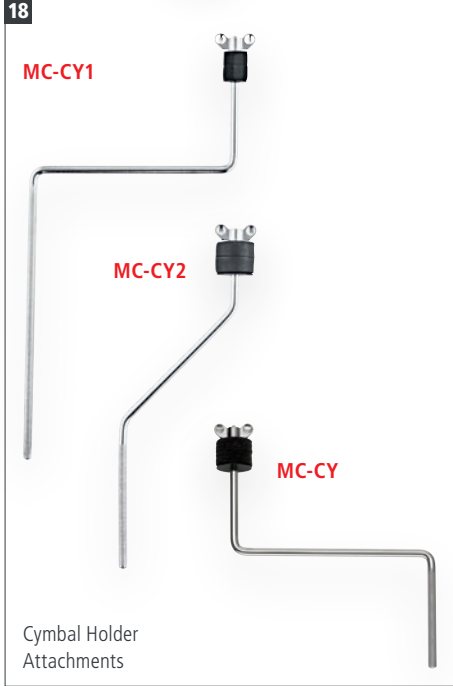

Cymbal Holder Attachments



Cymbal Attachment
MCA



X-Hat Cymbal Stand Adapter
MXHA



Double Extension Arm
MDEA



X-Hat Auxiliary Hihat Arm
MXH

14 MULTI CLAMP FOR CYMBAL STANDS

MATERIAL Chrome plated steel
FEATURES Double-sided clamp; Attach a cymbal or tom arm to any stand; Universal for all standard drum hardware; Metal body with durable synthetic thumb screws

15 PEDAL MOUNT

MATERIAL Black powder coated steel
FEATURES Height adjustable legs; Metal spikes; Fits on all common bass drum pedals and firmly holds cowbells, blocks, or tambourines
INCLUDES 2 differently sized L-rods

16 PEDAL MOUNT FOR CYMBALS

MATERIAL Black powder coated steel
FEATURES For foot activated cymbal crashes; Holds cymbals ranging from 16" to 22"
INCLUDES Cymbal arm

17 CYMBAL STACKERS

SIZES **MC-CYS:** Ø 6 mm, long
MC-CYS8: Ø 8 mm, long
MC-CYS8-S: Ø 8 mm, short
MATERIAL Chrome plated steel
FEATURE Felt washers

18 CYMBAL HOLDER ATTACHMENTS

MATERIAL Chrome plated steel
FEATURES Knurled surface; Felt washers; For splashes or small crashes; Easy placement on a drumkit, cajon set or percussion rig
MC-CY: Z-shaped 3/8" rod
MC-CY1: S-shaped 3/8" rod
MC-CY2: Z-shaped 3/8" rod with extra-long knurled end

19 X-HAT CYMBAL STAND ADAPTER

MATERIAL Chrome plated steel
FEATURES Turn any cymbal stand into an X-Hat stand; Fits 8 mm threaded cymbal stand posts; Use with any size hihat or stack

20 CYMBAL ATTACHMENT

MATERIAL Chrome plated steel
FEATURES Multi-clamp; Cymbal boom arm

21 DOUBLE EXTENSION ARM

MATERIAL Chrome plated steel
FEATURES Two points of 360-degree adjustability; Heavy-duty chrome plated steel; Length adjustable

22 X-HAT AUXILIARY HIHAT ARM

MATERIAL Chrome plated steel
FEATURE Easy to attach and position at any height or angle

HARDWARE



Mic. Cymbal Clamp Set
MPMCS



Mic. Drumset Clamp Set
MPMDS

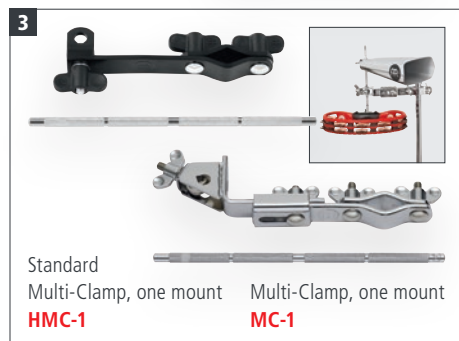

Standard Multi-Clamp, one mount
HMC-1 Multi-Clamp, one mount
MC-1

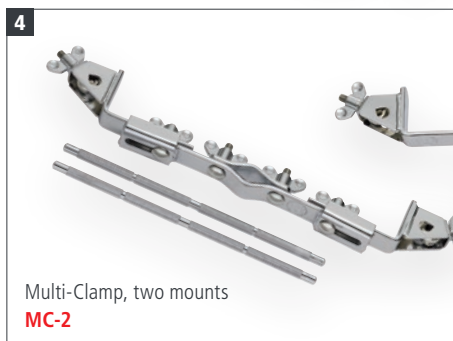

Multi-Clamp, two mounts
MC-2

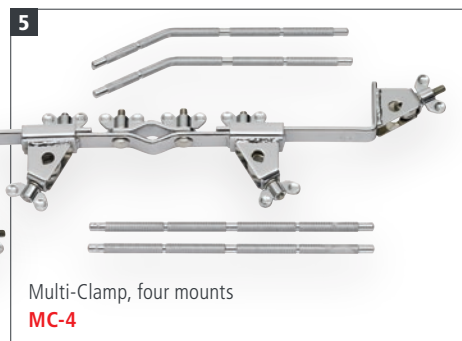

Multi-Clamp, four mounts
MC-4

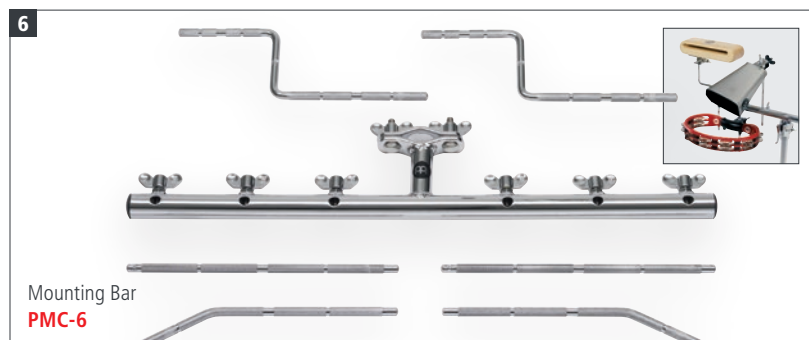

Mounting Bar
PMC-6

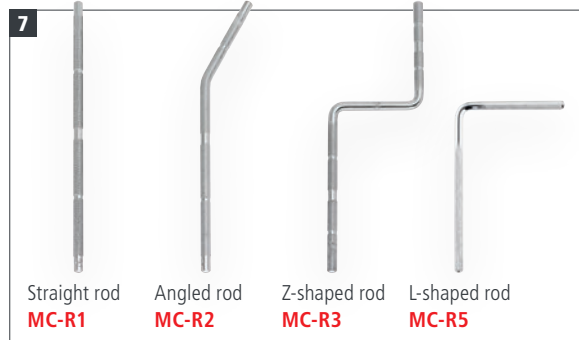

Straight rod **MC-R1** Angled rod **MC-R2** Z-shaped rod **MC-R3** L-shaped rod **MC-R5**

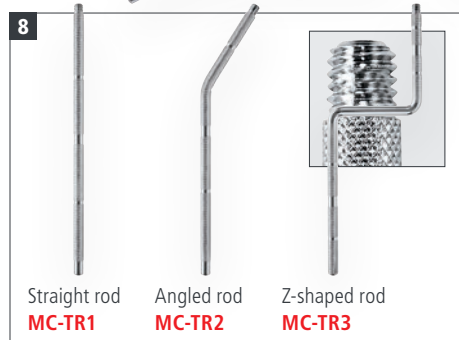

Straight rod **MC-TR1** Angled rod **MC-TR2** Z-shaped rod **MC-TR3**



Short rod **MC-MR1-S** Straight rod **MC-MR1** Angled rod **MC-MR2** Z-shaped rod **MC-MR3**

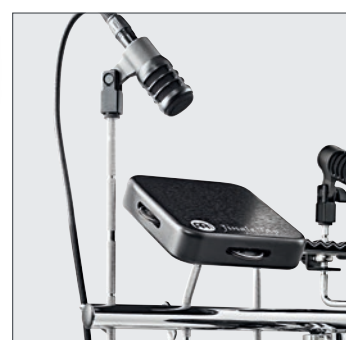

1 MICROPHONE CYMBAL CLAMP SET

CONTAINS 3 x Standard Multi-Clamp (HMC-1); 3 x Short Rod With Threaded Microphone Connector (MC-MR1-S); 1 x Microphone Rod Counter Nuts (MRCN5)

2 MICROPHONE DRUMSET CLAMP SET

CONTAINS 1 x Bass Drum Microphone Clamp (MC-MRBD); 4 x Rimclamp (RIMCLAMP-2); 4 x Short Rod With Threaded Microphone Connector (MC-MR1-S); 1 x Microphone Rod Counter Nuts (MRCN5)

3 MULTI-CLAMPS, ONE MOUNT

MATERIALS **HMC-1:** Black powder coated steel
MC-1: Chrome plated steel
FEATURES Strong mounting clamp
MC-1: Length adjustable
INCLUDES Straight rod

4 MULTI-CLAMP, TWO MOUNTS

MATERIAL Chrome plated steel
FEATURES Length adjustable; Strong mounting clamp
INCLUDES 2 straight rods

5 MULTI-CLAMP, FOUR MOUNTS

MATERIAL Chrome plated steel
FEATURES Length adjustable; Strong mounting clamp
INCLUDES 2 straight and 2 angled rods

6 MOUNTING BAR

MATERIAL Chrome plated steel
INCLUDES 2 straight, 2 angled and 2 z-shaped rods

7 RODS

MATERIAL Chrome plated steel
FEATURES Knurled surface; Available as a straight, angled, z-shaped, or l-shaped rod

8 THREADED PERCUSSION RODS

MATERIAL Chrome plated steel
FEATURE Threaded tip to mount any standard 3/8" threaded percussion instrument

9 RODS WITH THREADED MICROPHONE CONNECTOR

MATERIAL Chrome plated steel
FEATURES 3/8" diameter rod with threaded end; Designed to attach microphones; Use with the MEINL Rim Clamp; Available as a short, straight, angled, or z-shaped rod
INCLUDES Microphone screw adapter

10 BASS DRUM MICROPHONE CLAMP

MATERIAL Chrome plated steel
FEATURE U-shape 3/8" diameter rod with threaded end to attach a microphone



10
Bass Drum
Microphone Clamp
MC-MRBD



11
Set, 5 pcs.
Microphone Rod Counter Nuts
MRCN5



12
Flexible Microphone Gooseneck
FMG



13
Microphone
Cajon Clamp
MPMCC



14
Microphone
Adapter
TMMA



15
Clamp
CLAMP



16
Rim Clamps
RIMCLAMP-2

RIMCLAMP



RIMCLAMP-M

PERFECT MIC PLACEMENT ON
ANY COMMON DRUM RIM



17
Professional Multi-Clamps
TMPMC

TMPMC-R



TMPMC-G

STRONG CLAMP SECURES
TO ANY DRUM RIM

11 MICROPHONE ROD COUNTER NUTS

MATERIAL Black powder coated steel
FEATURES Set of 5 counter nuts; Securely lock your microphone attachments

12 FLEXIBLE MICROPHONE GOOSENECK

SIZE 12.8" (32.5 cm)
MATERIAL Metal
FEATURES Optimal microphone placement; No additional stand required; Fits in the MEINL Rim Clamp; 3/8" and 5/8" threads

13 MICROPHONE CAJON CLAMP

MATERIAL Steel
FEATURE Foam padding ensures quiet recording

14 MICROPHONE ADAPTER

MATERIAL Chrome plated steel
FEATURES Turns your cymbal stand into a microphone stand; 8 mm threaded attachment

INCLUDES 5/8" male to 3/8" mic screw adapter

15 CLAMP

MATERIAL Chrome plated steel
FEATURE Compact and solid design

16 RIM CLAMPS

MATERIALS Black powder coated steel
RIMCLAMP: Chrome plated steel (L-shaped rod)
RIMCLAMP-M: Metal (Gooseneck)
FEATURES Fully height and angle adjustable; Fits to any common drum rim
RIMCLAMP, RIMCLAMP-2: Holds percussion accessories right where you need them
RIMCLAMP-M: Works with all 3/8" or 5/8" mic clips (Mic clip not included)

INCLUDES **RIMCLAMP:** L-shaped rod
RIMCLAMP-M: Flexible Microphone Gooseneck

17 PROFESSIONAL MULTI-CLAMPS

MATERIALS Black powder coated die cast steel
TMPMC-G: Metal (Gooseneck)
TMPMC-R: Chrome plated steel (Z-shaped rod)
FEATURES 360-degree adjustable 3/8" rod eye bolt mount
TMPMC: Strong clamp secures to any drum set or percussion rim
TMPMC-G: Removable flexible microphone gooseneck; Strong clamp secures to any drum set or percussion rim
TMPMC-R: Removable Z-shaped 3/8" rod to mount percussion instruments

BAGS



BAGS

MATERIAL Heavy-duty nylon
(unless noted otherwise)

1 CAJON GIG BAG

SIZE 20 1/2" W x 12" H x 12" D

FEATURE Carrying grip

2 PROFESSIONAL CAJON BAGS

SIZES **MCJB, MCJB-CG:**

20 1/2" W x 12" H x 12" D

MCJB-L: 23 1/2" W x 17" H x 15" D

MATERIAL **MCJB-CG:** Ripstop Fabric

FEATURES Padded shoulder strap; External pocket; Carrying grip

MCJB-L: Fits bigger sized cajons

FINISH **MCJB-CG:** Carbon Grey

3 DELUXE CAJON BAG

SIZE 20 1/2" W x 12" H x 12" D

FEATURES Synthetic fur; Padded shoulder strap; External pocket; Carrying grip

4 DELUXE BASS PEDAL CAJON BAG

SIZE 21 1/2" W x 17" H x 14 1/2" D

FEATURES Synthetic fur; Padded shoulder strap; External pocket; Carrying grip

5 CAJON BACKPACK

SIZE 13 1/2" W x 19 3/4" H x 14" D

FEATURES Backpack; Carrying grip

6 JAM CAJON GIG BAG

SIZE 12" W x 16" H x 12" D

FEATURES Fits all Jam Cajon models; Strong carrying grip; Two-way zipper

7 TRAVEL CAJON GIG BAG

SIZE 12"

FEATURES Double-slide zipper; Carrying grip

8 PROFESSIONAL SLAPTOP CAJON BAG

SIZE 23" W x 15" H x 13" D

FEATURES Padded shoulder strap; External pocket; Carrying grip

9 CAIXON & CAIXONET BAG

SIZE 31" W x 12 1/2" H x 13 1/2" D

FEATURES Carrying handle with reinforced nylon stitching; Durable zipper; Adjustable shoulder strap; Fits caiXoN and caiXoNet stacked or individual

FEATURES Padded shoulder strap; Carrying grip

10 PROFESSIONAL HYBRID SLAPTOP CAJON BAG

SIZE 17 1/2" W x 13" H x 8" D

MSTDJB10 **MSTDJB12**
STANDARD DJEMBE BAGS

MDJB-S **MDJB-M** **MDJB-L** **MDJB-XL**
PRO DJEMBE BAGS

MSTDJB
DJEMBE GIG BAG

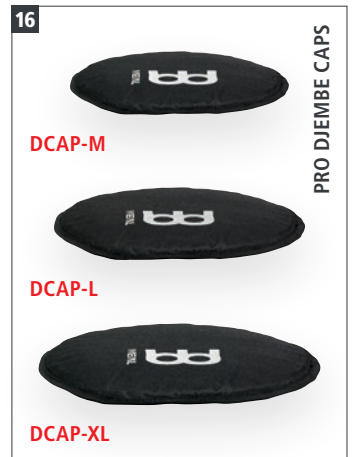
VR-DJB-9 **VR-DJB-10** **VR-DJB-12** **VR-DJB-14**
POP OFF DJEMBE BAGS

DCAP-M
DCAP-L
DCAP-XL
PRO DJEMBE CAPS

MSTCOB
CONGA GIG BAG

MCOB-11 **MCOB-1134** **MCOB-1212**
PRO CONGA BAGS

VR-CSETB
POP OFF CONGA SET BAG
11 MULTI-PERCUSSION BAG

SIZE 21" W x 12" H x 15" D
FEATURES Padded shoulder strap; External pocket; Carrying grip; Padded dividers

12 STANDARD DJEMBE BAGS

SIZES **MSTDJB10**: Medium (10")
MSTDJB12: Large (12")
FEATURES External pocket; Carrying grip

13 PROFESSIONAL DJEMBE BAGS

SIZES **S**: Small (up to 10")
M: Medium (up to 12")
L: Large (up to 13 1/2")
XL: XL: Extra large (up to 14")
FEATURES External pocket; Carrying grip
MDJB-M, MDJB-L, MDJB-XL: Padded backpack straps

14 DJEMBE GIG BAG

FEATURES Carrying grip; Shoulder strap; Outer pocket

15 POP OFF DJEMBE BAGS

SIZES **VR-DJB-9**: 11 1/2" x 17 1/4"
VR-DJB-10: 11 3/4" x 19 3/4"
VR-DJB-12: 13 3/4" x 24 1/2"
VR-DJB-14: 15 3/4" x 27 1/2"
FEATURES Carrying handle with reinforced nylon stitching; Durable zipper; Adjustable backpack straps
VR-DJB-9 Holds 8" & 9" diameter djembes
VR-DJB-10 Holds 10" diameter djembes
VR-DJB-12 Holds 12" diameter djembes
VR-DJB-14 Holds 14" diameter djembes

16 PROFESSIONAL DJEMBE CAPS

SIZES **M**: 10"; **L**: 12"; **XL**: 13"

17 CONGA GIG BAG

FEATURES Carrying grip; Shoulder strap; Outer pocket

18 PROFESSIONAL CONGA BAGS

SIZES **MCOB-11**: 11"
MCOB-1134: 11 3/4"
MCOB-1212: 12 1/2"
FEATURES Additional upright zipper; External pocket; Padded backpack straps; Carrying grip

19 POP OFF CONGA SET BAG

SIZE 13" x 26"
FEATURES Carrying handle with reinforced nylon stitching; Durable zipper; Adjustable backpack straps; Carry all three sizes of MEINL Pop Off Congas

BAGS



BAGS

MATERIAL Heavy-duty nylon (unless noted otherwise)

1 BONGO GIG BAG

SIZE Bongos up to 7 1/2" Macho & 8 1/2" Hembra
FEATURE Carrying grip

2 PROFESSIONAL BONGO BAG

FEATURES Additional room for accessories; Padded shoulder strap; Carrying grip; Padded separator

3 PROFESSIONAL TIMBALES BAG

SIZE 14" & 15"
FEATURES External pocket for stand and cowbell; Padded shoulder strap; Carrying grip; Padded separator

4 PROFESSIONAL SURDO BAGS

SIZES **MSUB-16:** 16" x 20"
MSUB-18: 18" x 22"
MSUB-20: 20" x 24"
MSUB-22: 22" x 24"

FEATURES Double-slide zipper; Padded backpack straps; Carrying grip; External pocket

5 PROFESSIONAL TIMBA BAGS

SIZES **MTIMB-1428:** 14" x 28"
MTIMB-1435: 14" x 35"

FEATURES Double-slide zipper; Padded backpack straps; Carrying grip; External pocket

6 STACK DRUM SET BAG

SIZE 13 1/2" x 24 1/2"
FEATURES Carrying handle with reinforced nylon stitching; Durable zipper; Adjustable backpack straps; Carry both sizes of MEINL Stack Drum Set

7 POP OFF BASS DRUM SET BAG

SIZE 16 1/4" x 25 1/4"
FEATURES Carrying handle with reinforced nylon stitching; Durable zipper; Adjustable backpack straps; Carry all three sizes of MEINL Pop Off Bass Drums

8 PROFESSIONAL TANTAM BAG

SIZE 14" x 28"
FEATURES Double-slide zipper; Padded backpack straps; Carrying grip; External pocket

9 PROFESSIONAL REBOLO BAG

SIZE 12" x 18"
FEATURES Double-slide zipper; Padded shoulder strap; Carrying grip; External pocket

10 PROFESSIONAL REPINIQUE BAGS

SIZES **MREB-10:** 10" x 10"
MREB-12: 12" x 12"



PRO REPINIQUE BAGS

MREB-10 MREB-12



PRO CUIÇA BAGS

MQW-6 MQW-10



PRO CAIXA BAGS

MCA-12 MCA-12T MCA-14



PRO CHIMES BAG

MCHB



PRO FRAME DRUM BAGS

MFDB-14 MFDB-16 MFDB-18 MFDB-20 MFDB-22



PRO DEEP SHELL FRAME DRUM BAGS

MFDB-12BE MFDB-14BE MFDB-14IBO MFDB-18BO MFDB-22-D



PRO PANDEIRO BAGS

MPAB-10 MPAB-12



TAMBOURINE GIG BAG

MSTTB



PRO TAMBORIM BAG

MTAB-06



PRO KANJIRA BAG

MFDB-7KA

FEATURES Double-slide zipper; Shoulder strap; Carrying grip; External pocket

11 PROFESSIONAL CUIÇA BAGS

SIZES MQW-6: 6"
MQW-10: 10"

FEATURES Padded shoulder strap; Carrying grip; External pocket

12 PROFESSIONAL CAIXA BAGS

SIZES MCA-12: 12" x 4 1/2"
MCA-12T: 12" x 6"
MCA-14: 14" x 4"

FEATURES Double-slide zipper; Shoulder strap; Extra pocket for spare heads; Carrying grip; External pocket

13 PROFESSIONAL CHIMES BAG

FEATURES Stores up to 2 chimes; Carrying grip; Inner hook and loop fastener straps;

2 internal pockets

14 PROFESSIONAL FRAME DRUM BAGS

SIZES MFDB-14: 14", 2 1/2" deep
MFDB-16: 16", 2 1/2" deep
MFDB-18: 18", 2 1/2" deep
MFDB-20: 20", 2 1/2" deep
MFDB-22: 22", 2 1/2" deep

FEATURES Double-slide zipper; Shoulder strap; Carrying grip

15 PROFESSIONAL DEEP SHELL FRAME DRUM BAGS

SIZES MFDB-12BE: 12" x 4"
MFDB-14BE: 14" x 4"
MFDB-14IBO: 14" x 6"
MFDB-18BO: 18" x 4"
MFDB-22-D: 22" x 4"

FEATURES Double-slide zipper; Shoulder strap; Carrying grip

16 PROFESSIONAL PANDEIRO BAGS

SIZES MPAB-10: 10"; MPAB-12: 12"

FEATURES Double-slide zipper; Shoulder strap; External pocket
MPAB-12: Also fits for our 10" Tambourines

17 TAMBOURINE GIG BAG

SIZE 10"
FEATURES Sturdy zipper; Carrying grip

18 PROFESSIONAL TAMBORIM BAG

SIZE 6"
FEATURES Double-slide zipper; Shoulder strap; External pocket

19 PROFESSIONAL KANJIRA BAG

SIZE 8 1/2" x 2 1/2"
FEATURES Double-slide zipper; Shoulder strap; External pocket

BAGS



BAGS

MATERIAL Heavy-duty nylon
(unless noted otherwise)

1 STANDARD DARBUKA BAG

SIZE Medium
FEATURES Carrying grip; Shoulder strap; Outer pocket

2 PROFESSIONAL DARBUKA BAG

FEATURES Double-slide zipper; Additional upright zipper; Padded shoulder strap; Carrying grip; External pocket

3 PROFESSIONAL IBO BAGS

SIZES **S:** Small (9 3/4" W x 13 1/3" H x 9 3/4" D)
M: Medium (11" W x 14 1/2" H x 11" D)
L: Large (11 3/4" W x 15" H x 11 3/4" D)
FEATURES Padded shoulder strap; Carrying grip; External pocket

4 STANDARD DOUMBЕК BAG

SIZE Medium
FEATURES Carrying grip; Shoulder strap; Outer pocket

5 PROFESSIONAL DOUMBЕК BAGS

SIZES **MDOB:** Medium
MDOB-L: Large
FEATURES Double-slide zipper; Additional upright zipper; Padded shoulder strap; Carrying grip; External pocket

6 STRAIGHT DIDGERIDOO BAG

SIZE 53"
FEATURES Padded shoulder strap; External pocket

7 PRO DIDGERIDOO BAG

SIZE 58"
FEATURES Padded shoulder strap; External pocket

8 PERCUSSION BACKPACK

MATERIAL Ripstop Fabric
FEATURES Travel backpack for small percussion instruments; Numerous pockets on the inside and outside; Padded backpack shoulder straps; Carrying grip
FINISH Carbon Grey

9 HAND PERCUSSION BAGS

SIZES **M:** Medium
L: Large
FEATURES Great for cowbells, blocks or small hand percussion; Drawstring top; Durable nylon prevents scuffs and scratches; No hassle storage or travel

10 COMPACT STICK BAG

FEATURE Carrying grip

BAGS & DRUM RUGS



MCSB



MSB-1



MDLXSB



MSSB



DRUM RUGS



BAGS & DRUM RUGS

11 PROFESSIONAL STICK BAG

FEATURES External pockets; Shoulder straps; Extension straps
COLOUR Black

12 DELUXE STICK BAG

MATERIAL Padded synthetic leather
FEATURES External pockets; Shoulder straps; Elastic cord attachments

13 STICK SLING BAG

FEATURES Wider version of our Professional Stick Bag; Eleven internal pockets of varying size for any kind of stick, mallet, rod, brush or accessory; Oversized exterior pocket that can fit books, sheet music, practice pads or metronomes

14 DRUM RUGS

SIZES **MDRS:** 5.25 ft (160 cm) x 4.6 ft (140 cm)
MDRL: 6.5 ft (200 cm) x 6.5 ft (200 cm)

MATERIAL Woven fabric
FEATURES **MDRS**

Tightly woven fabric creates a strong grip with spurs and stands; Durable no-slip rubber bottom; Compact size for smaller drum or percussion setups; Ideal for smaller stage footprint

MDRL

Durable no-slip rubber bottom; Full-size for any drum or percussion setup; Ideal for drum risers

INCLUDES Travel bag
Strap

FINISHES **BK:** Black
OR: Oriental

MEINL PERCUSSION ONLINE



DISCLAIMER MEINL PERCUSSION

All features are subject to change without notice. Not responsible for typographic errors. No part of this book may be reprinted, reproduced, or included in any online service in any form in whole or in part, without the prior permission of MEINL.

© 2024 Roland Meinl Musikinstrumente GmbH & Co. KG

ADVERTISING CONCEPT & DESIGN

ercas GmbH & Co. KG [ercasdieagentur.de]

CONTENT & DIRECTION

Hannes Auerochs, Udo Heubeck

COPYWRITING

Hannes Auerochs, Ayrton Gauerke

PHOTOGRAPHY

Christian Habermeier, Sebastian Jäger, Angelika Jakobs
[studio-waldeck.de]

Miroslav Šmikmátor [smikmatorphoto.com]

Tobias Winklmann, Yannick Steinicke, Danny Lucenara,
Hannes Auerochs, Manuel Burdeus Mendoza, Jan Potsch,
Niklas Sakowski

Thomas Bönig, Paul Höppner, Christian Schemm

LITHOGRAPHY

Sven Mihm [mihm-werbung.de]

GLOBAL HEADQUARTERS

Roland Meinl Musikinstrumente GmbH & Co. KG
Musik-Meinl-Straße 1
91468 Gutenstetten
Germany

US HEADQUARTERS

MEINL USA L.C.
3427 Ambrose Avenue
Nashville, TN 37207
USA

INVENTORS OF SELECTED PRODUCTS

Bill Saragosa

Dany Moreno

Gilson Batista Da Silveira

José J. Cortijo

Juan Carlos Melian

Marcus Ralph De Mowbray

Mark Allen Johnson

Michael Buchner

Reiko Guthschmidt

Taku Hirano

Torsten Franz

REMO®, Fiberskyn®, Nuskyn® and Skyndeeep®
are registered trademarks of REMO® Inc.
Used by permission.

